

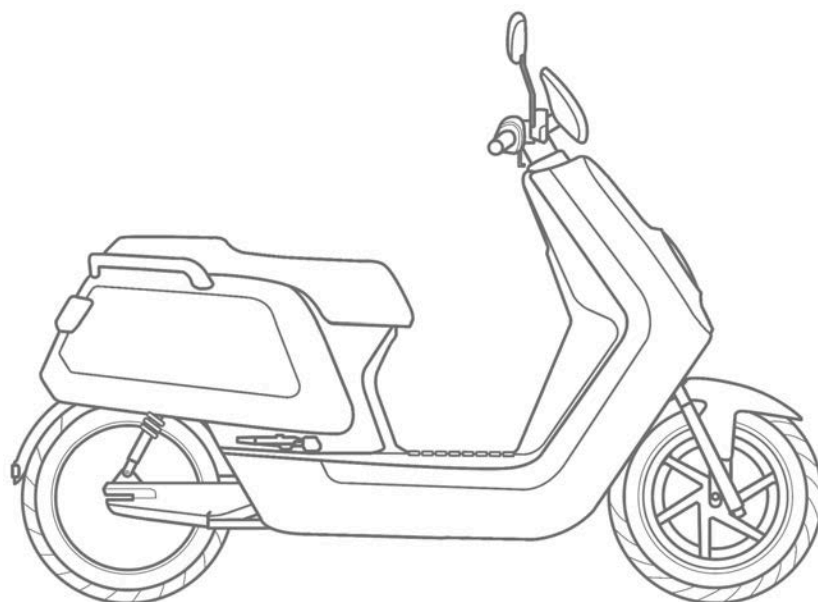

N Scooter

Service Manual



Jiangsu Niu Electric Technology Co. Ltd



Maintenance Information

The maintenance and reparation information contained in this manual is for technical specialists only. Maintenance or reparation performed by those who are not trained properly and provided with appropriate tools and equipment may cause injuries to themselves or others and also lead to damages or unsafe conditions of the scooter.

The proper maintenance and reparation procedures, some of which require special tools and equipment, are described in this manual. The risks in terms of personal safety and scooter operation safety, which may be resulted from the use of components, maintenance procedures or tools not recommended by Niu, must be verified.

Please make replacement with original electric components made by Niu or equivalents that have corresponding part numbers. We strongly recommend you not to use inferior components.

Customer Safety Notice

The proper maintenance is crucial for customer safety and scooter reliability. Any errors or omissions in scooter maintenance may result in operating malfunctions, scooter damages or injuries.

Improper maintenance or reparation may lead to unsafe conditions under which serious injuries or even death of your customers or other people may be incurred.

Please carefully follow the procedures and cautions in this manual and other maintenance materials.

Personal Safety Notice

This manual is used only by professional maintenance technicians, and the warning information about multiple basic workshop safety operation procedures (such as the procedure that requires gloves when working on hot components) is not set forth herein. We recommend you not to carry out procedures specified in this manual without readiness if you have not received the workshop safety training or grasped the knowledge about maintenance safety specifications.

The following are listed as several most importance general notes to maintenance safety. However, we are unable to set forth the warning for each of risks that may arise from maintenance and reparation procedures. You have to determine at your discretion whether a detail task should be implemented.

Failure to properly follow relevant instructions and notes may result in serious injuries or even death. Please carefully follow procedures and notes in this manual.



Importance Safety Notes

Make sure that you have completely understood basic workshop operation safety procedures and taken on proper protective clothes and are provided with safety equipment. Extra attention should be paid to the following in the implementation of a maintenance task:

- Read all the relevant instructions before operation, and make sure that you have necessary tools, spare parts, components and skills to implement a maintenance task safely and completely.
- There are high-voltage circuits in the scooter system, which can cause electric shock. It must be verified that your maintenance site, tools, protective equipment and operation procedures are in compliance with the insulation requirement.
- Eyes should be protected with proper safety glasses, goggles or masks in operations such as hammering, drilling, polishing or prying or working around high-pressure air or fluid tanks, springs or other energy storage components. Eye protection devices should be worn as long as there are suspicious conditions.
- Other protection devices such as gloves or safety shoes are used where necessary. Gloves should be worn before handling of a hot or sharp component that may cause serious burns or cuts or grasping of any things that may cause injuries.
- Measures should be taken to protect you and others once a scooter is lifted. Make sure that the scooter is always supported stably when being lifted with a crane or jacks. Please use jack mounts.
- The hot motor after driving for a long time may cause burns. Wait for the motor to cool down before working on it.
- Moving parts can cause injuries. Make sure that your hands, fingers and clothes are not obstructive.
- Components must be cleaned with non-flammable solvents instead of the gasoline.
- All components related to a storage battery should be away from cigarettes, sparks and flames.



Contents

Foreword	5
Maintenance Rules and Important notes	6
Cable connector inspection	7
Scooter Identification	8
Specifications	9
Part Names	12
Parts Removal and Installation Procedure	18
Front Wheel	42
Front Fork	44
Steering Handlebar	46
Rear Wheel/ Rear Suspension	48
Brake System	51
Lithium battery/charger	58
Electrical System	
Main Harness diagram	63
Check Main Harness communication	64
Circuit diagram	66
Electronic components	67
Diagnostic Code	115
Regular Maintenance Checklist	131



Foreword

Key points in maintenance of Niu N1S are described in this maintenance manual.

Preparations in the maintenance manual include notes to all operations. Please read the manual carefully before operating.

Key points in the inspection and adjustment, including maintenance methods for scooter safety and component performance that are applied from regular examinations, are described.

Chapters are edited with disassembly diagrams, system figures and instructions about the maintenance and failure diagnosis.

Note:

Modifications of scooter version or structure as well as photos, pictures or instructions in the manual are referred to physical objects without further notice.



Maintenance Rules

1. Metric tools should be made as available as possible in the maintenance of the scooter. Use of improper tools may damage the scooter.
2. Clean off the dirt outside parts or assemblies of the chassis or braking system before guard removal from the scooter or opening for maintenance.
3. Please clean parts and blow them with an air compressor after removal and before measurement of the wearing value.
4. Rubber parts that have become aged or deteriorated are very easy to be damaged by the solvent or oil. They should be checked or replaced if necessary before reassembly.
5. Multiple assemblies should be loosened in the sequence from outside to inside and beginning with small ones.
6. Complex assemblies should be stored in a proper installation sequence for further assembling.
7. Extra attention should be paid to important fitting positions before disassembling. Parts that are no longer to be used should be replaced before disassembly.
8. The bolt or screw length varies with assemblies and guards. Bolts or screws must be installed at correct positions. A bolt can be placed into a bolt hole for fitness in case of confusion
9. The oil seal should be installed by lubricant application into the oil seal groove, and should be checked for smoothness, smoothness and damages before installation.
10. The spherical bearings (on the front wheel-hub or rear wheel motor) should be removed by holding one or two bearing races (the inner and outer races) with tools. The bearing may be damaged in removal if the force is applied only to one race (the inner or outer race) and thus must be replaced.

Important notes

1. Please use original parts made by Niu. Use of components that are not in compliance with design specifications by Niu Company may cause damages to the scooter.
2. Maintenance operations can be performed only with metric tools. The metric bolts, nuts and screws can not be interchanged with British fasteners.
3. The replacement with new washers, O rings, split pins and lock shims should be made for reassembly.
4. Bolts or nuts should be tightened by beginning with large-diameter bolts or inward bolts and then gradually tightening to specified torques diagonally, unless otherwise indicated.
5. Clean components that have been removed with the detergent solution. All the sliding faces should be lubricated before assembling.
6. Check all components for the proper installation and operating after assembly.
7. Remove the dirt and oil stains before measurement. Apply recommended lubricants to sections to be lubricated during assembly.
8. Apply the lubricant to part surfaces to avoid rusting and dust accumulation, if the engine and transmission systems need to be stored for a long time after disassembling.



Cable connector inspection

- Loose cables constitute a risk to electric safety. Cables should be checked after their clamping to ensure electric safety.
- Bending of cable clamps towards welding points is not allowed.
- Cables are bound at designated positions.
- Cable placement at the scooter frame end or a sharp angle is not allowed.
- Cable placement at the bolt or screw end is not allowed.
- Cable placement should be made away from thermal sources or positions where cables may be stuck in moving.
- The cable placement along stem handles should not be made too tight or loose and should not interfere with adjacent parts at any steering positions.
- Cables should be placed smoothly without being twisted or tied.
- Verify whether the connector shroud is damaged or the connector is excessively open before connecting.
- Please protect the cable at a sharp angle or turning position with adhesive tapes or a hose.
- Cables should be bound reliably with adhesive tapes after reparation.
- Controlling cables should not be bent or twisted. The controlling would not be flexible if controlling cables were damaged.



Scooter Identification

- Vehicle serial number (SN) is in the user manual

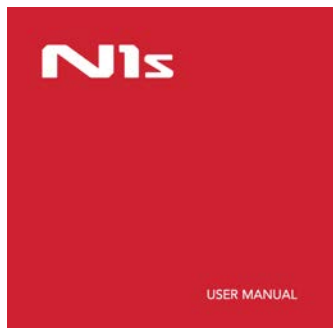

- The scooter frame identification code (VIN) is made on the rear frame at rear seat cask.



- The frame namepad is riveted above the dual supports at right side of the frame.

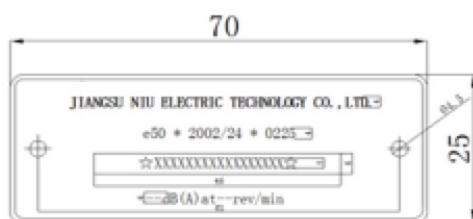

- The anti-altering is at inner right side of the seat cask.

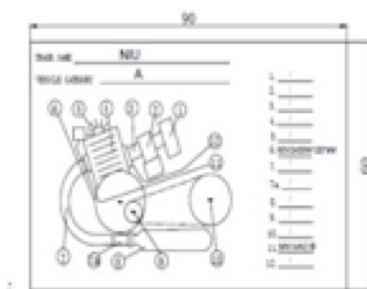

- The motor code is made at left side of the wheel-hub motor.





Overall specifications

Item		Specifications
Dimensions	Length x width x height	1800x700x1130 mm
	Wheelbase	1280mm
	Complete vehicle kerb mass	90Kg
	Ground clearance of the seat cushion	740mm
	Ground clearance	140mm
Scooter frame	Type of the scooter frame	The pedal type made with combined welding of panels and pipes
	Specifications of the front tire	90/90-12
	Type of the front rim	2.15X12 aluminum alloy rim
	Air pressure of the front tire	175KPa
	Specification of the rear tire	120/70-12
	Type of the rear wheel	3.50X12 wheel-hub motor
	Air pressure of the rear tire	250KPa
Suspension	Front shock absorber	Telescopic type with 31mm dual hydraulics
	Rear shock absorber	Telescopic type with dual hydraulic springs
Brake	Type of the front brake	Single sided hydraulic brake with dual pistons
	Type of the rear brake	Opposed sided hydraulic brake with dual pistons



Specifications of the motor controller system

Item		Specifications
Motor	Motor type	Brushless permanent-magnet motor
	Controller type	FOC vector control
	Rated voltage	DC60V
	Rated power	1500W
	Maximum motor power	2400W
	Maximum motor torque	120N*m
Controller	Rated voltage	DC60V
	Undervoltage protection	51.4V
	Maximum current of the controller	40A

Specifications of the battery/charger

Item		Specifications
Battery	Type	Enclosed lithium battery
	Rated voltage	60V
	Rated capacity	20Ah-30Ah
Charger	Rated output voltage	71.4V
	Rated output current	3-4A



Specifications of the braking system

Item	Standard value (mm)	Minimum Thickness(mm)
Diameter of the front brake disc	φ220mm	-
Thickness of the front brake disc	4.0	3.0
Thickness of the front brake pad	4.0	3.0
brake fluid	DOT3 or DOT4	
Diameter of the rear brake disc	φ180mm	-
Thickness of the rear brake disc	3.5	2.5
Thickness of the rear brake pad	4.5	3.0
brake fluid	DOT3 or DOT4	

Specifications of the Lighting/Display/switch

Electric system	
Item	Specifications
Front headlight	12V LED
Turn signal lamp	12V LED
Rear tail lamp	12V LED
Brake lamp	12V LED
Display	12V LCD display
Central control unit	12V
USB charging interface	5V



Part Names

Scooter body/scooter body panel





Front Wheel

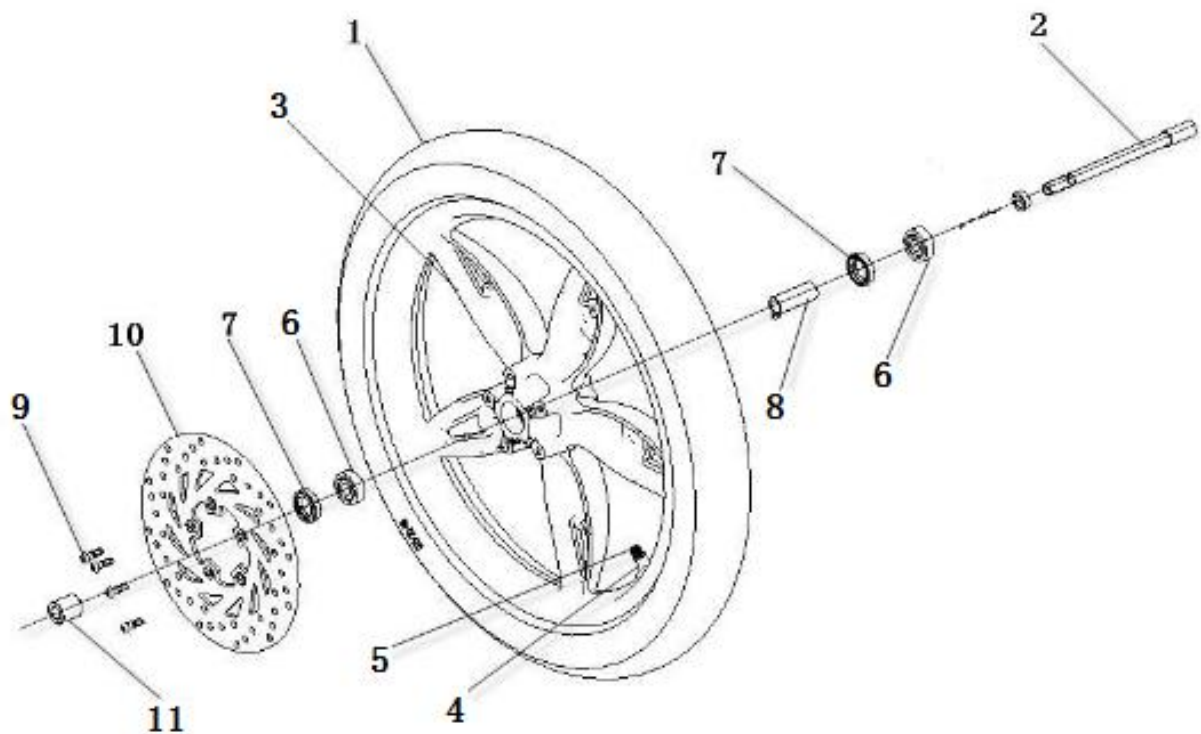

1. Front Tire 2. Front Wheel Axle 3. Front Alloy Wheel 4. Valve 5. Valve Cap
6. Front Wheel Oil-seal 7. Bearing 8. Intermediate Spacer on the front wheel
9. Screw M6x20 10. Front Brake Disc 11. Outer Spacer on the front wheel



Front Fork

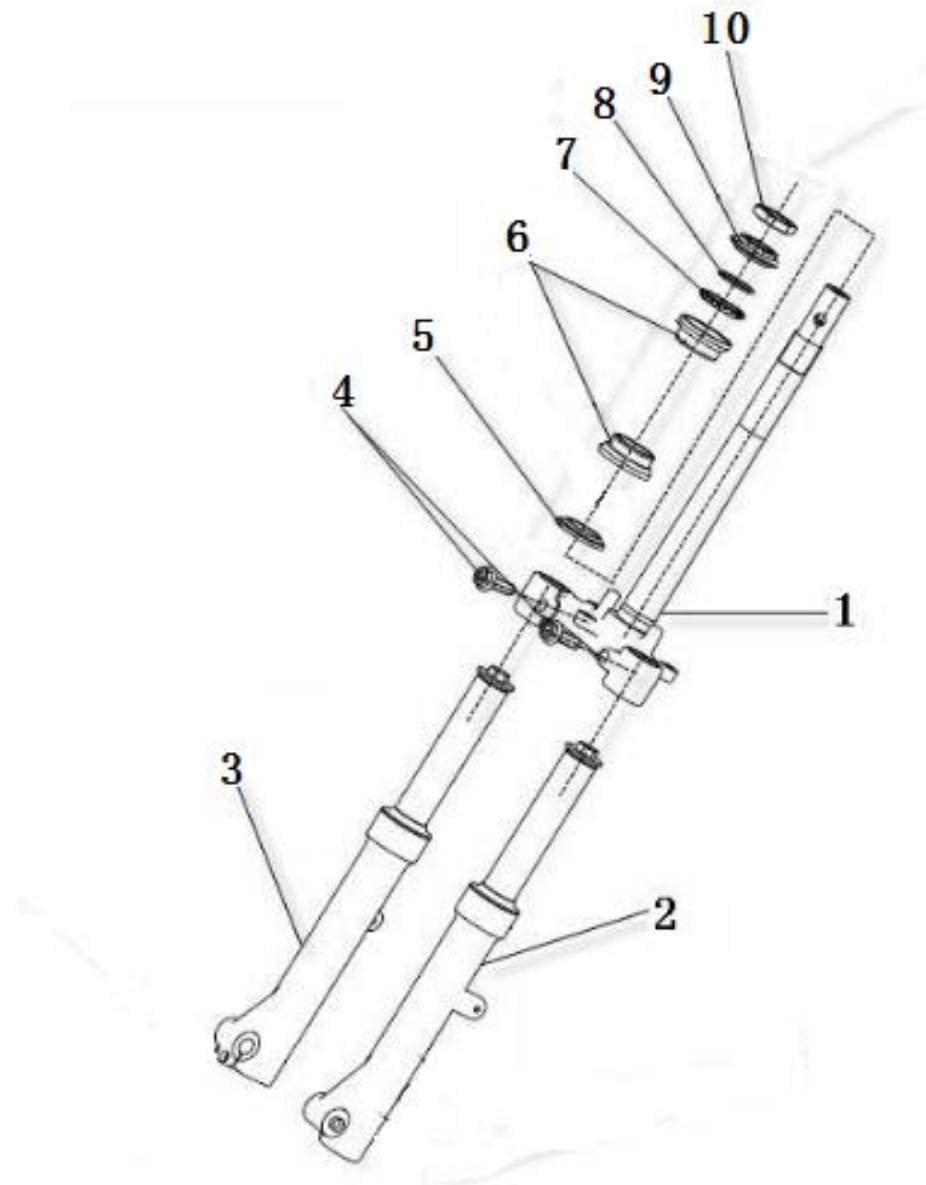

1. Welded lower yoke plate assembly 2. Front left shock absorber assembly
3. Front right shock absorber assembly 4. Bolt M10×1.25 5. Lower conical bearing
6. Outer race of the upper conical bearing 7. Upper conical bearing
8. Bearing cover 9. Lock nut 10. Gland nut



Steering Handlebar

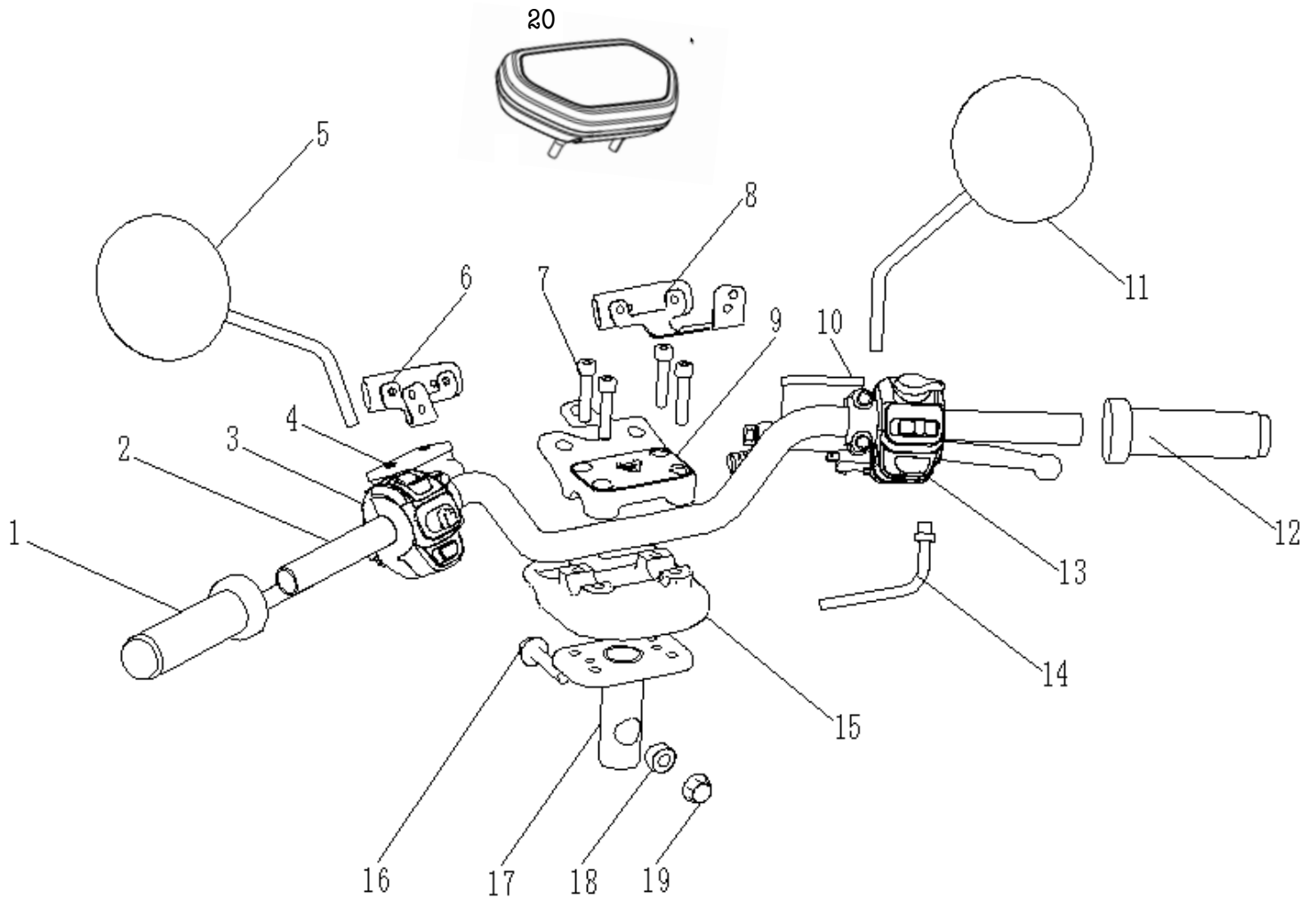

1. Left handle glove 2. Steering handle assembly 3. Left combination switch 4. Rear brake 5. Left rear-view mirror 6. Left turn signal lamp 7. Hex socket bolt M10 8. Right turn signal lamp 9. Upper press block on the scooter handle 10. Front brake 11. Right rear-view mirror 12. Twist Grip 13. Right combination switch 14. Accelerator cable 15. Grip end collar 16. Hex flange bolt M10 17. T-shape board 18. Fixed block 19. Nut M10 20. Display



Rear Wheel/ Rear Suspension

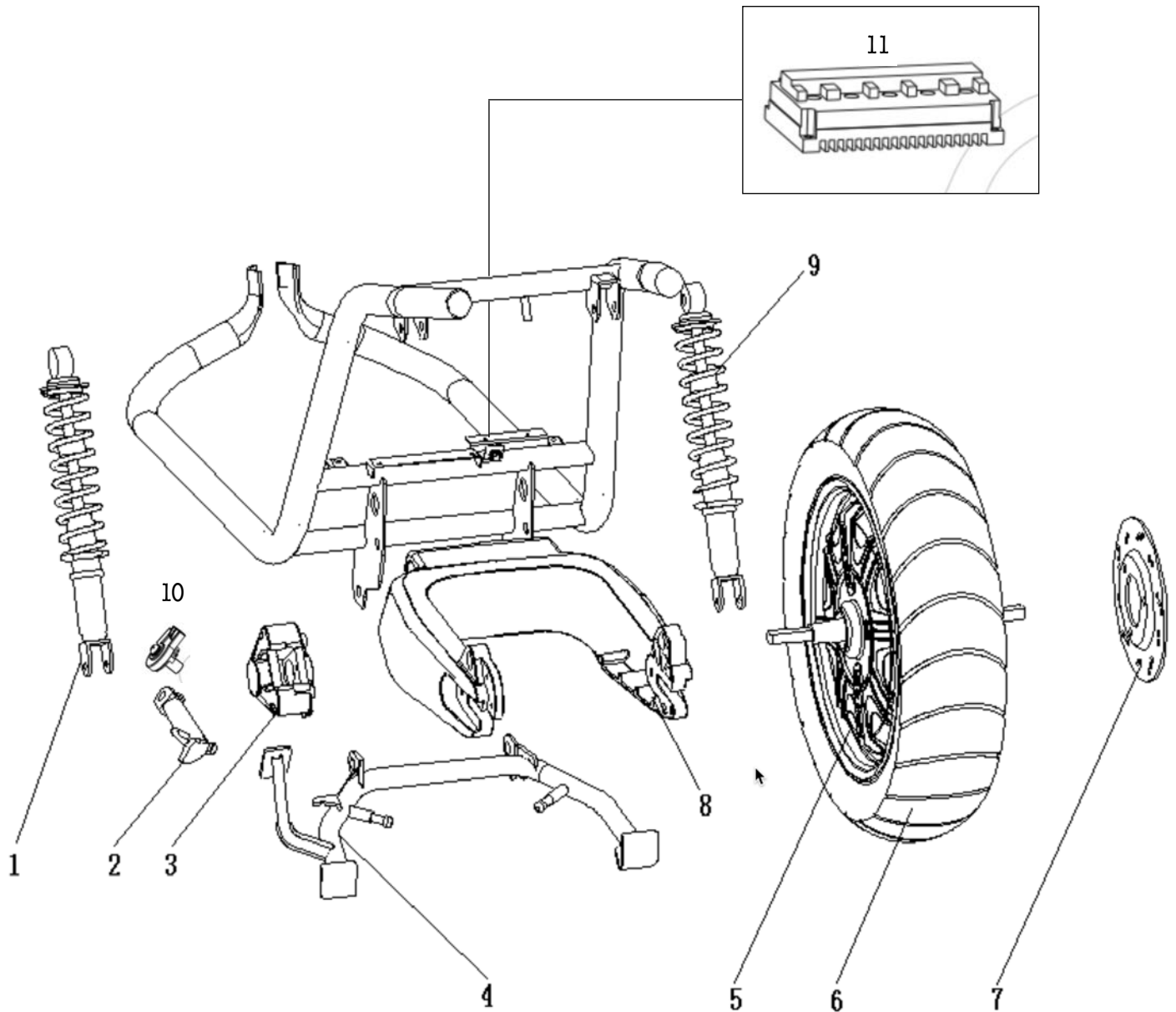

1. Left rear shock absorber 2. Side support 3. Rear brake 4. Kickstand 5. Motor 6. Vacuum tire 7. Rear brake disc 8. Rear bottom fork 9. Right rear shock absorber 10. Side Stand Switch 11. FOC Controller



Electronic Components

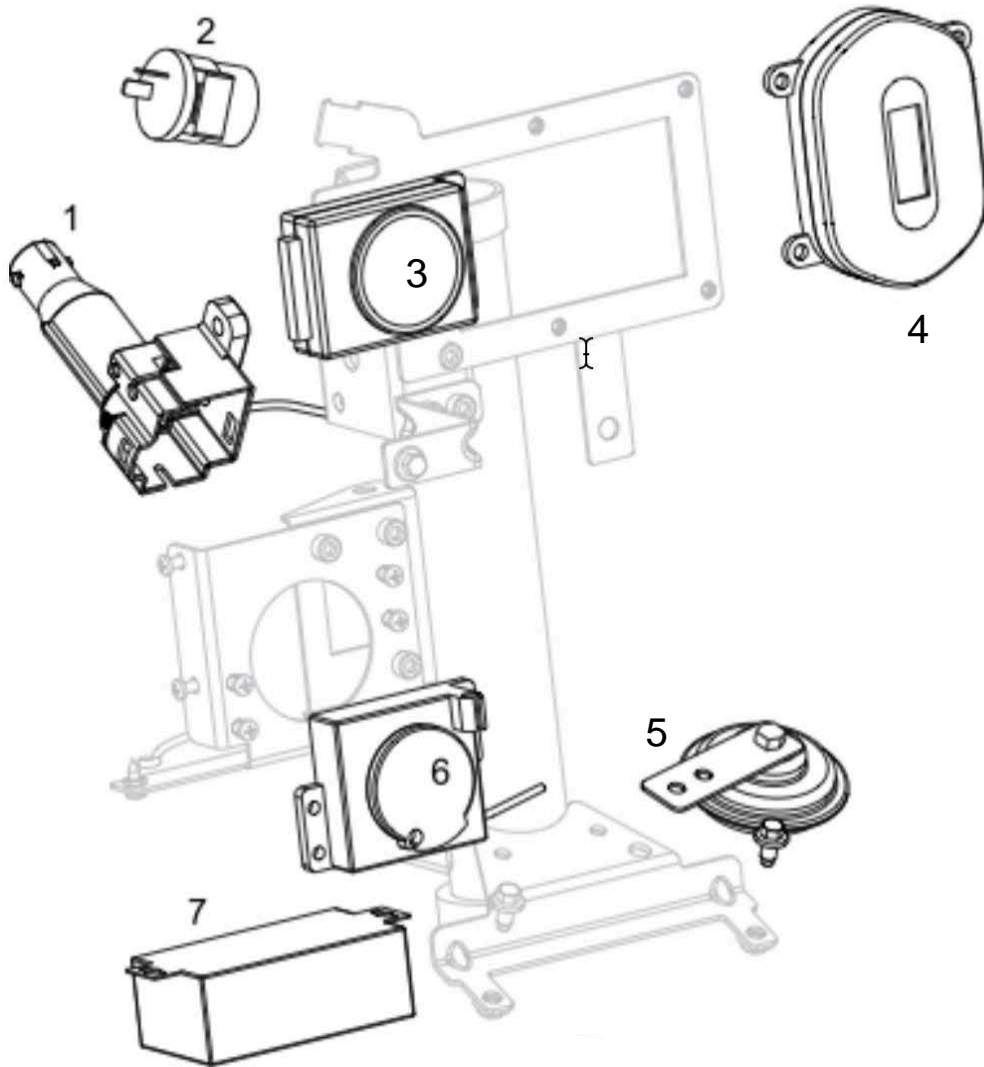

1. Power Lock 2. Flasher 3. Alarm 4. ECU 5.Horn 6. Cable Hall Sensor 7.DC-DC converter



Parts Removal and Installation Procedure

Procedures for removal and installation of scooter body panels are described in this section. The ignition switch and main switch (if applicable) must be turned to OFF before disconnection or connection of electric units, when the storage battery has been installed onto the scooter.

Note

- Do not damage scooter body coverages in disassembling/assembling.
- Do not damage hooks and claws on scooter body coverages in disassembling/assembling.
- Align the embedded panels and covers on scooter coverages with their respective grooves.
- Hooks and claws at various sections should be installed properly during assembly.

1. Windshield

1.1 Unscrew two screws on the Windshield



2. Front Neck Cover

2.1 Remove two Front Central Cover Rubber Plugs and unscrew two screws inside



2.2 Remove Front Neck Cover by lifting it at front





3. Front Panel

3.1 Unscrew two screws on the top of Front Panel



3.2 Take out two Push-in Rivets from the bottom of Front Panel



3.3 Remove Front Panel by pushing it upward





4. Under Seat Storage Compartment

4.1 Unscrew four screws in the Under Seat Storage Compartment



4.2 Lift up the Under Seat Storage Compartment, disconnect the two connectors



4.3 Pull Battery Compartment Lock cable out





5. Rear Central Cover

5.1 Unscrew the left side screw



5.2 Unscrew the right side screw



5.3 Pull out the rubber cover and unscrew the screw



5.4 Pull out Rear Central Cover carefully





6. Battery Compartment Cover and Footrest

6.1 Pull out the footrest plug and unscrew two hexagon flange bolt



6.2 Unscrew four cross recessed pan head tapping screws and remove Battery Compartment Cover



6.3 Unscrew two hexagon flange bolts



6.4 Unscrew right side screw





6. Battery Compartment Cover and Footrest

6.5 Unscrew left side screw



6.6 Pull out the Footrest





7. Side Panel

7.1 Unscrew left side screw



7.2 Unscrew two screws in dark side



7.3 Pull out the whole side panel





8. Handrail

8.1 Remove four Hexagon flange bolts marked in the guide photo

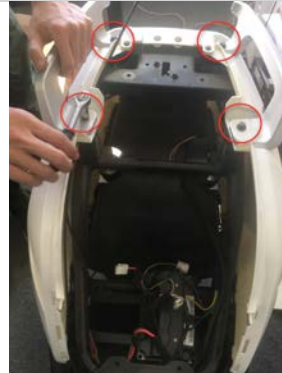

8.2 Pull out the Handrail





9. End cap and Body Cover

9.1 Unscrew four cross recessed medium pan head bolts

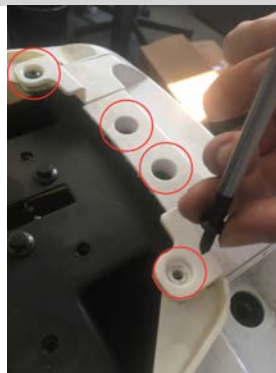

9.2 Unscrew Cross recessed pan head tapping screw



9.3 Unscrew two cross recessed pan head tapping screws

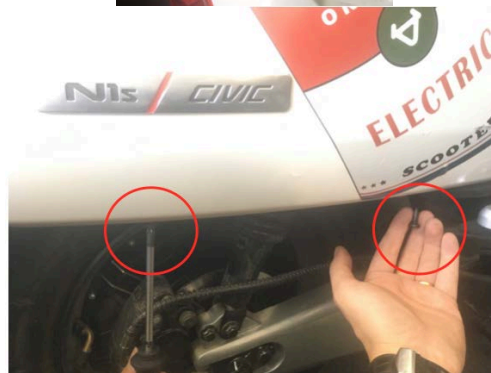

9.4 Pull out the whole body panel





10. Left/Right Central Cover and Foot pegs

10.1 Unscrew the Cross recessed pan head tapping screw



10.2 Unscrew the Cross recessed medium pan head bolt



10.3 Pull out the whole Left/Right Central Cover





10. Left/Right Central Cover and Foot pegs

10.4 Remove two socket head bolts



10.5 Take out the Foot Pegs





11. Front Left/Right Panel

11.1 Pull out two front glove compartment bolt hole plugs and unscrew the cross recessed pan head tapping screw inside



11.2 Take out Plastic Expansion Clips from the bottom of Front Left/Right Panel



11.3 Unscrew three screws in the right picture which line out red circle





11. Front Left/Right Panel

11.4 Unscrew the screw on the top of Front Right/Left Panel



11.5 Have a close-up view of panel jack and take out panel carefully





12. Helmet Hook

12.1 Unscrew the cross recessed medium pan head bolt



12.1 Pull the Helmet Hook out





13. Front Central Cover

13.1 Unscrew two cross recessed pan head bolt



13.2 Unscrew the power lock cover screw and take out the cover

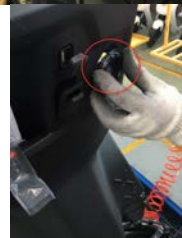

13.3 Unplug USB output cable



13.4 Take out whole Front Central Cover





14. Power Lock

14.1 Unscrew three Cross recessed pan head bolts



14.2 Unplug the Power Lock connector and take out the Power Lock

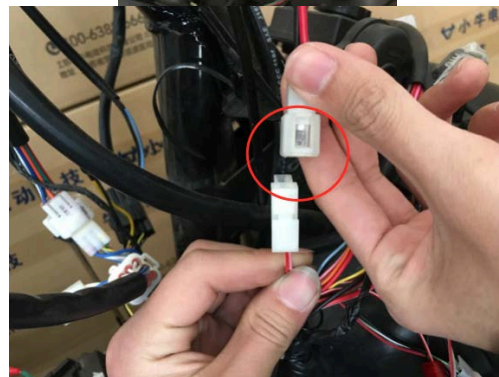



15. Front Wheel Cover

15.1 Unscrew 2 Cross recessed medium pan head screw and 2 Cross recessed pan head tapping screw

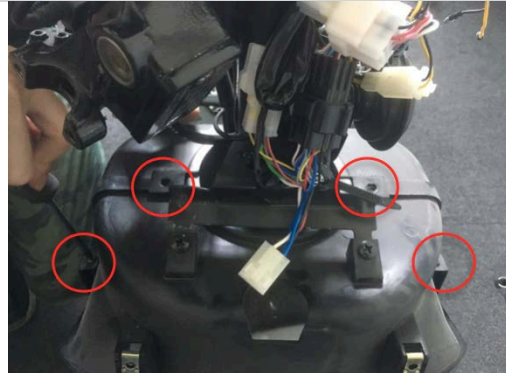

15.2 Pull out the whole front wheel cover





16. Display

16.1 Unscrew three Hexagon flange nuts



16.2 Unplug dashboard cable and take out the Display





17. Brake System

17.1 Unscrew two Hexagon socket head stepped bolts marked in the guide photo



17.2 Pull out the cover



17.3 Plug Brake connector





17. Brake System

17.4 Unscrew one cross recessed pan head bolt and two Hexagon flange bolts then take out front Brake System



17.5 Unscrew two Hexagon socket head stepped bolts marked in the guide photo



17.6 Unscrew two cross recessed pan head bolt and take out Rear Brake System

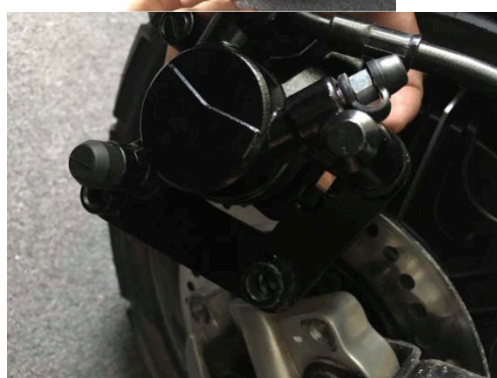



18. Side Stand and Side Stand Switch

18.1 Unscrew the screw and unplug the connector marked in guide photo to take out the side stand switch



18.2 Unscrew the side stand screw and take out the side stand and spring
(spring hook on the red circle when installation)





19. Front Fender and Rear Fender

19.1 Unscrew two Hexagon flange bolts on the left and right sides then take out the Rear Fender



19.2 Unscrew two Cross recessed medium pan head bolts on the left and right sides then take out the Front Fender





20. Motor

20.1 Unscrew two hexagon flange bolts on the left and right side



20.2 Remove the motor connectors on FOC controller





20. Motor

20.3 Unplug the motor hall connector (Scooters produced before 2016 Dec) then pull out Motor





Front Wheel

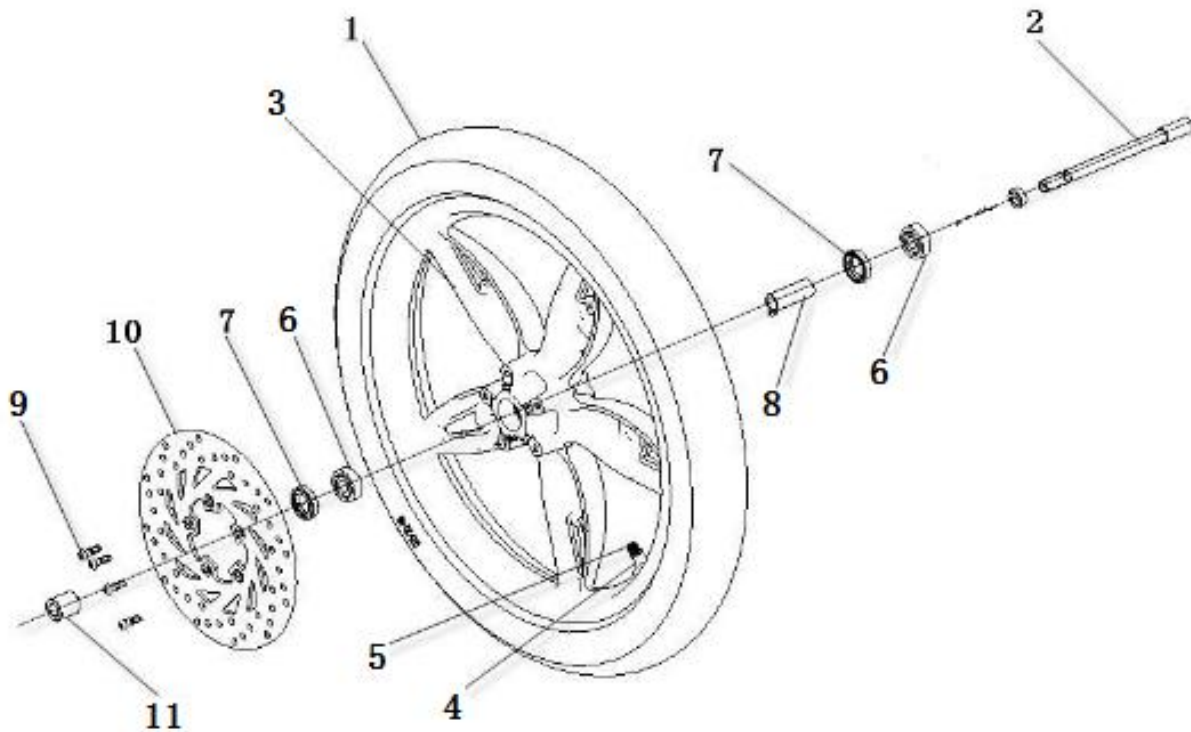

1. Front Tire 2. Front Wheel Axle 3. Front Alloy Wheel 4. Valve 5. Valve Cap
6. Front Wheel Oil-seal 7. Bearing 8. Intermediate Spacer on the front wheel
9. Screw M6x20 10. Front Brake Disc 11. Outer Spacer on the front wheel

Specifications of the front tire: 90/90-12

Installation torque value for screw 11 in the figure: 8Nm

Installation torque value for Axle 2 in the figure: 60Nm

Rim run-out limits: 2.0mm

Vertical limit: 2.0mm

Lateral limit: 2.0mm

Deflection limit of the front axle: 0.2mm



Front Wheel

Failure diagnosis

- The tire pressure is too low.
- There is air leakage from the tire.
- The tire pressure is insufficient.
- The front axle is deflected.
- The front wheel tire is deformed and the tire is deflected.
- The front wheel oscillates.
- The wheel is deformed.
- The front axle bearing becomes loosened.
- The tire is deteriorated.
- The wheel is difficult to turn.
- The axle bearing failed or the braking is bad.
- The front axle is deflected.
- The front brake is applied.

Inspection

Inspection of the rim oscillation

- Place the wheel on a precise support.
- Check the rim oscillation.
- Manually turn the wheel to read the oscillation value.

Inspection of the front wheel bearing

- Remove the front axle and front brake disc.
- Remove outer spacer on the front wheel, and then remove the front wheel oil-seal.
- Remove the bearing.
- Remove the intermediate spacer.
- Check the bearing rotation.
- The bearing that does not rotate is worn or loosened. Replace it with a new one.

Disassembling

Coming soon...



Front Fork

Specifications of the Front Fork

Installation torque value for screw 4 in the figure: 28Nm

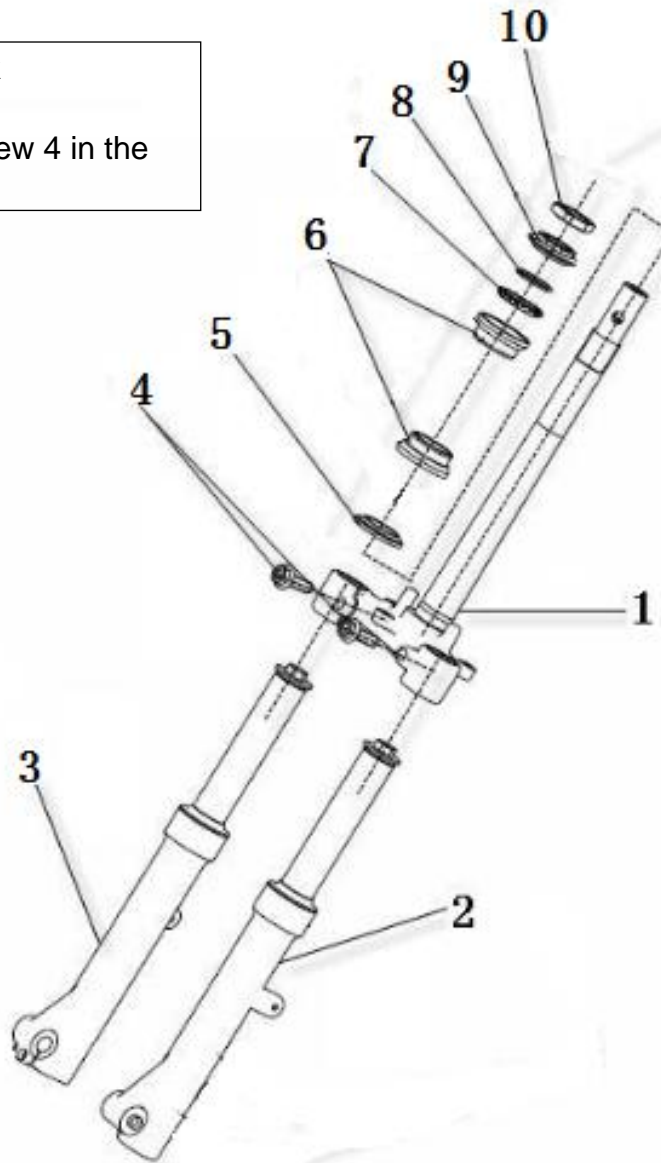

1. Welded lower yoke plate assembly
2. Front left shock absorber assembly
3. Front right shock absorber assembly
4. Bolt M10x1.25
5. Lower conical bearing
6. Outer race of the upper conical bearing
7. Upper conical bearing
8. Bearing cover
9. Lock nut
10. Gland nut



Front Fork

Failure diagnosis

The front fork is deflected.

There is an abnormal noise from the front shock absorber.

Bolts on the shock absorber are loosened.

The liquid in the front shock absorber is insufficient.

Disassembling

Remove the panel, front journal lid and front fender.

Remove the steering handle assembly.

Sequentially remove:

Gland nut, lock nut, bearing cover and

upper conical bearing

Remove the front fork.

Remove the lower conical bearing.

Remove tightening bolts from the front shock absorber.

Remove the front left and right shock absorber assemblies.

Tools:

Spanner for tightening bolts on the steering handle.

Dedicated bearing detacher.



Steering Handlebar

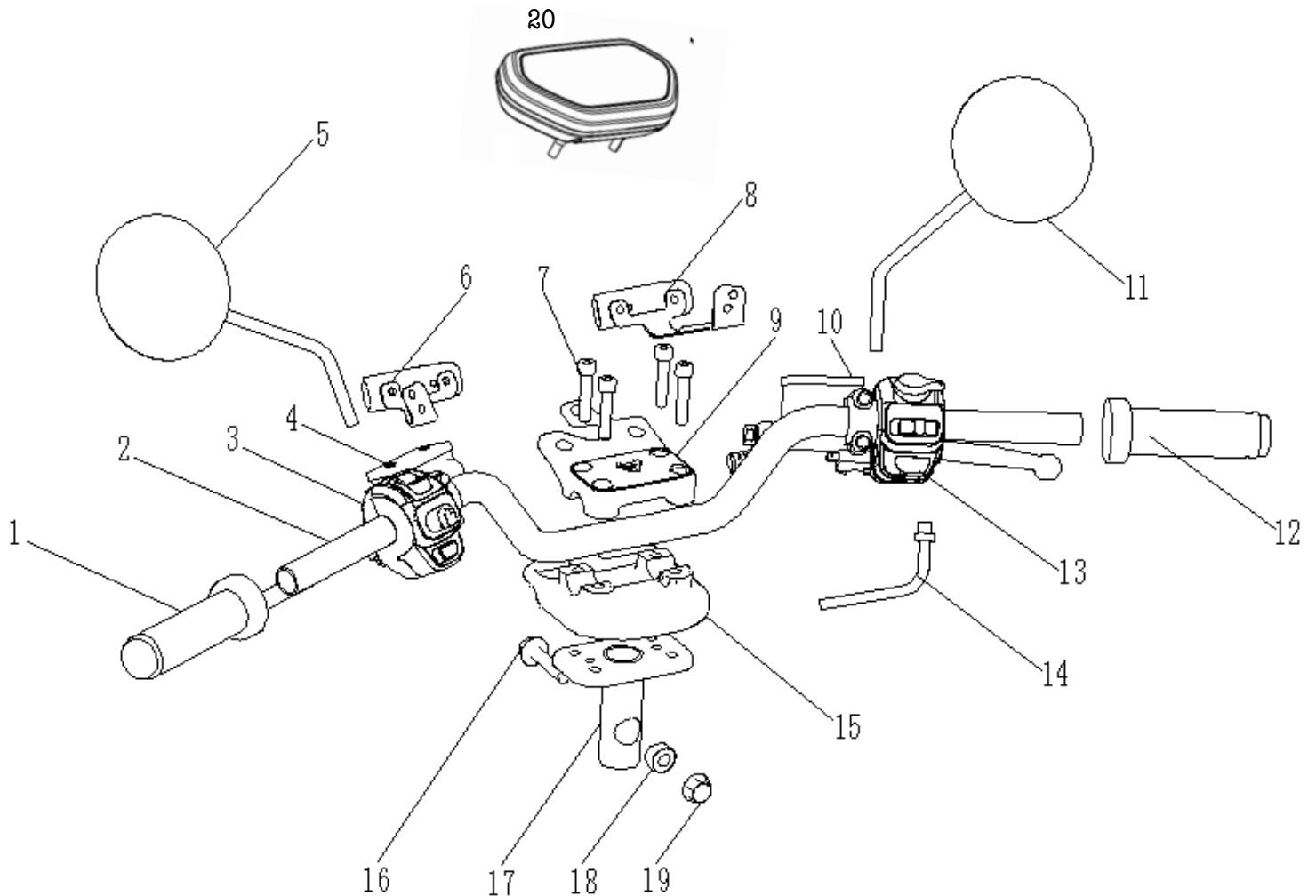

1. Left handle 2. Steering handlebar 3. Left combination switch 4. Rear brake 5. Left rear-view mirror 6. Left turn signal lamp 7. Hex socket bolt M10 8. Right turn signal lamp 9. Upper press block on the scooter handle 10. Front brake 11. Right rear-view mirror 12. Twist grip 13. Right combination switch 14. Accelerator cable 15. Grip end collar 16. Hex flange bolt M10 17. T-shape board 18. Fixed block 19. Nut M10 20. Display

Specifications of the Steering Handlebar

Installation torque value for screw 16 in the figure: 52Nm

Front/Rear Brake Lever free travel distance: 7-15mm

Twist Grip free travel distance: 5-10mm



Steering Handlebar

Failure diagnosis

The steering handle is difficult to turn.

The steering handle bearing failed.

The steering handle bearing is damaged.

Steering is unstable

The steering handle bearing is damaged.

Disassembling

Remove the left and right rear-view mirror assemblies (5) and (11).

Remove the left and right grasp handle assemblies (1) and (12).

Remove the accelerator cable assembly (14).

Remove the left and right combination switched (3) and (13).

Remove the rear brake (4).

Remove the front brake (10).

Remove upper and lower press blocks (9) and (15) on the scooter handle.



Rear Wheel/ Rear Suspension

Rear Suspension

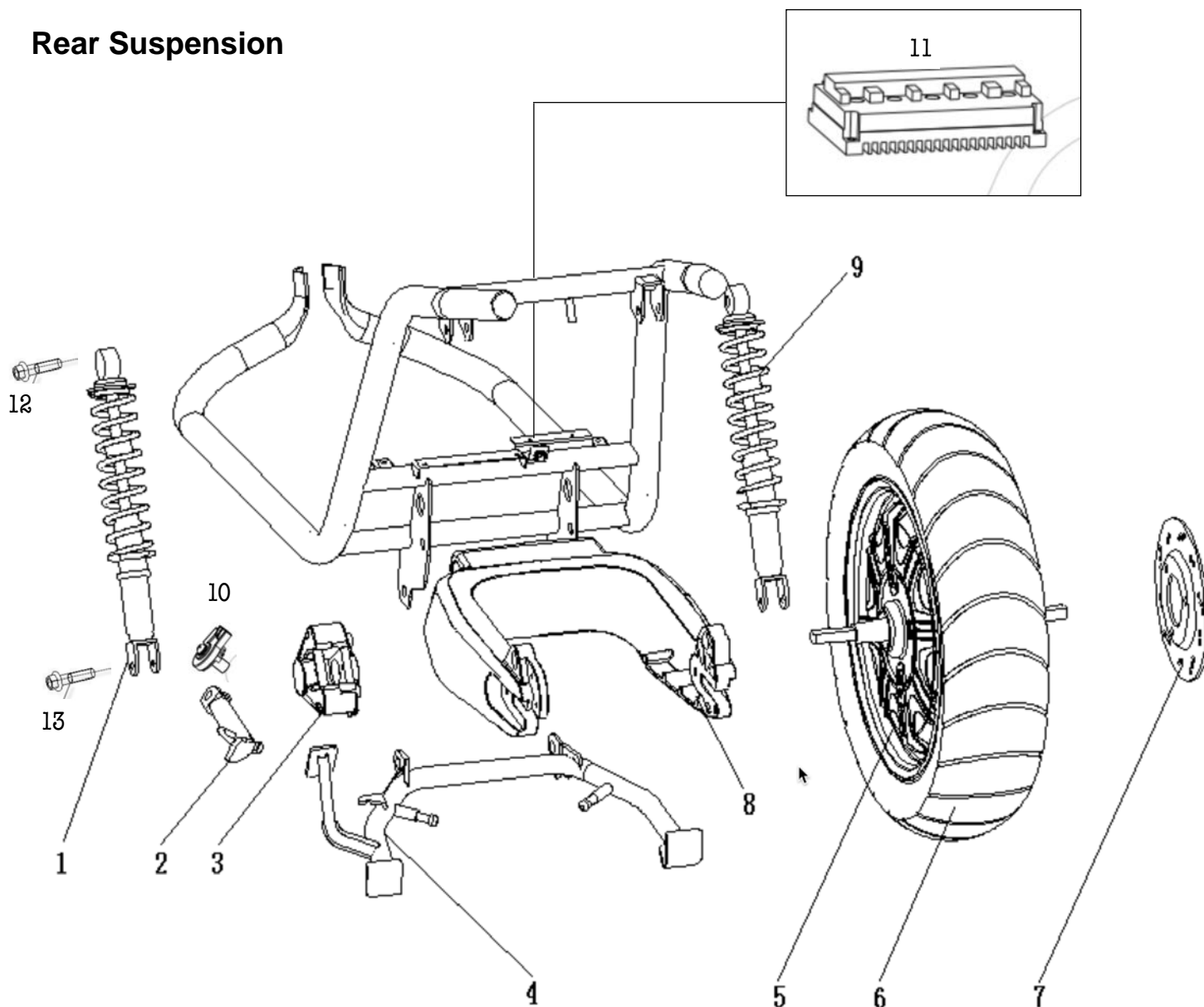

1. Left rear shock absorber 2. Side support 3. Rear brake 4. Kickstand 5. Motor 6. Vacuum tire 7. Rear brake disc 8. Rear bottom fork 9. Right rear shock absorber 10. Side Stand Switch 11. FOC Controller 12. Top Bolts on the rear shock absorber 13. Bottom Bolts on the rear shock absorber

Diameter of the rear brake disc:
 $\phi 180\text{mm}$

Thickness of the rear brake disc: 3.5mm
Operating limit: 2.5mm

Torque value for Top Bolts on the rear shock absorber: 44Nm
Torque value for Bottom Bolts on the rear shock absorber: 28Nm



Motor

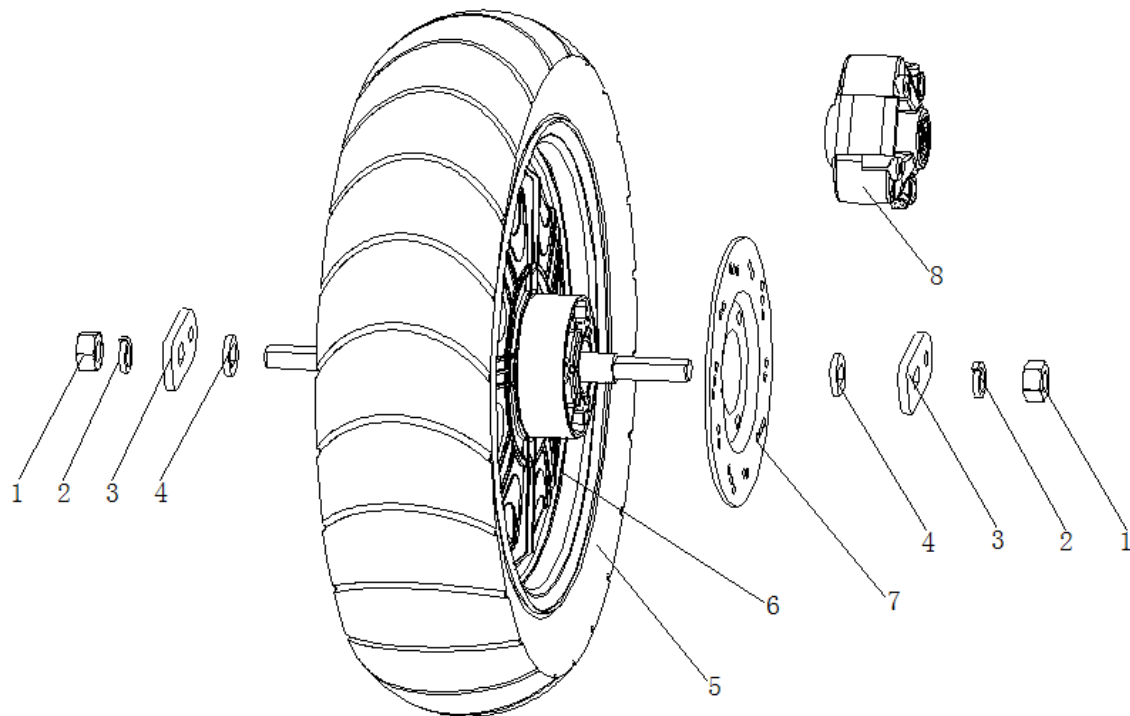

1. Self-locking nut 2. Spring washer 3. Lock washer 4. Locating washer 5. Vacuum tire 120/90-12 6. Motor 7. Brake disc 8. Rear disc brake pump

Specifications of the Motor

Installation torque value for self-locking nut 1 in the figure: 75Nm

Motor oscillation value :

Vertical oscillation limit : 2.0mm

Lateral oscillation limit : 2.0mm



Failure diagnosis

Oscillation of the rear wheel
Deformation of the motor rim
Motor failure
Motor un-tightened
Bearing loosened or worn
Insufficient tyre pressure
Shock absorber softened excessively
Insufficient spring elasticity
Oil leakage from shock absorber
No elasticity of the rear shock absorber spring
Extremely low tyre pressure
Shock absorber hardened excessively
Shock absorber rod deflected
Extremely high tyre pressure
Abnormal noise from the rear suspension
Rear suspension liner thinned and softened
Failure of the rear shock absorber

Disassembling Rear Absorber

Remove the seat cushion assembly and the scooter body assembly.
Loosen tightening bolts on top of the rear shock absorber.
Loosen tightening bolts on bottom of the rear shock absorber.
Remove the rear shock absorber.

Disassembling Motor

Remove lock nuts from the motor.
Remove motor connection wires.
Remove the motor assembly.



Brake System

Front Brake

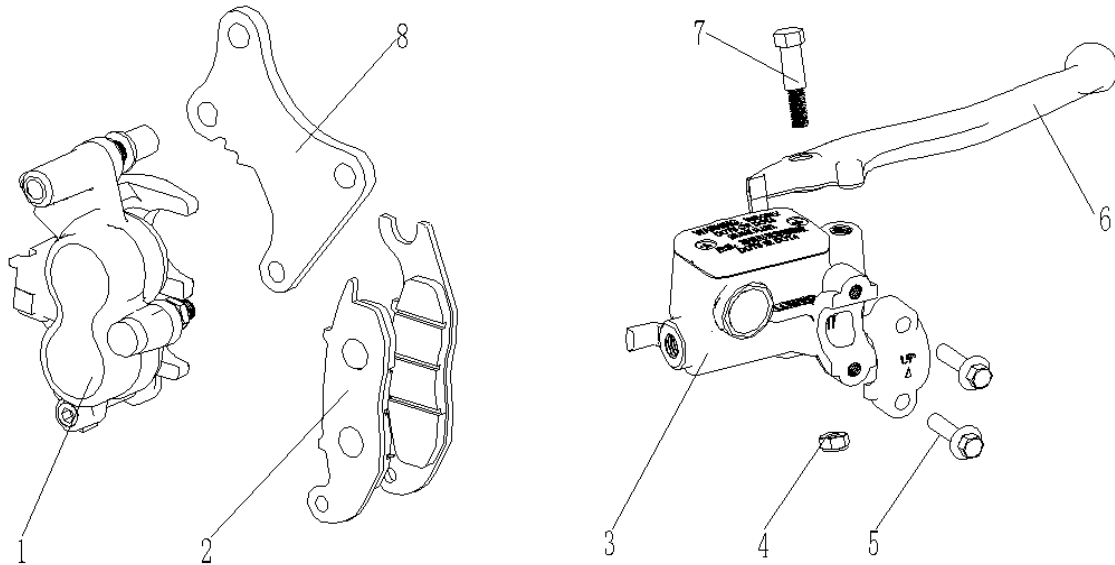

1. Front Disc Brake Lower Fluid Bump 2. Front Disc Brake Pad Set 3. Front disc brake Top Fluid Reservoir 4. Bolt M6 5. Screw M6 6. Front Disc Brake Lever 7. Tightening bolts on the handle 8. Installation board

Diameter of the front brake disc:
 $\varnothing 220\text{mm}$

Thickness of the front brake disc: 4.0mm
Operating limit: 3.0mm

Installation torque value for bolt 5 in the figure: 8 Nm

Free travel of the front disc brake lever:
7-15mm



Brake System

Rear Brake

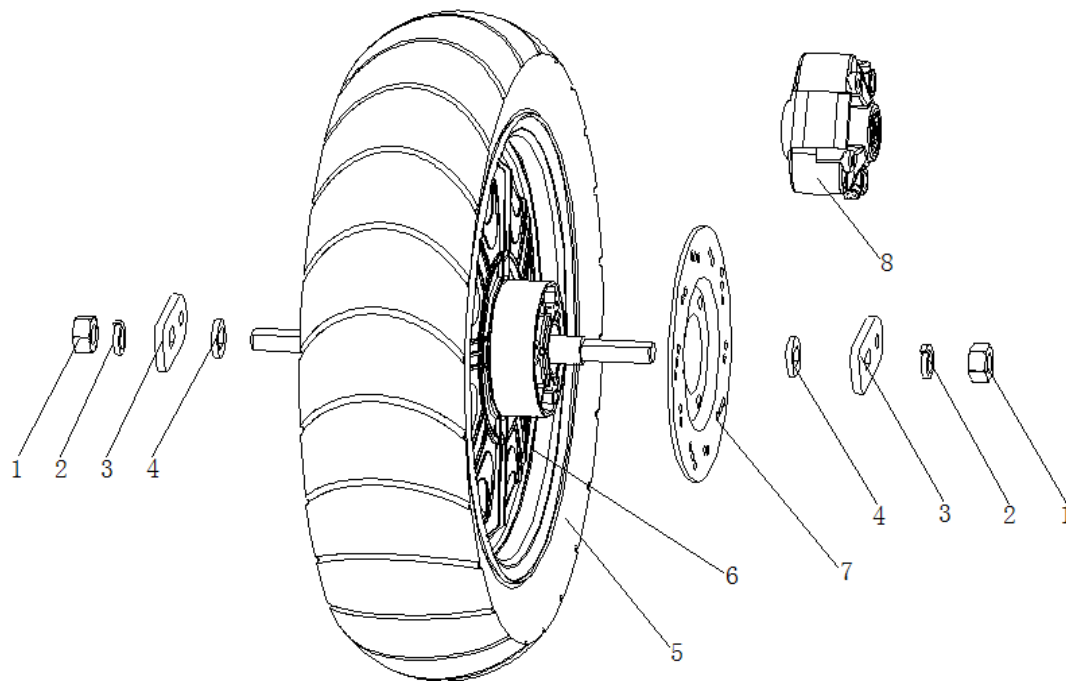

1. Self-locking nut 2. Spring washer 3. Lock washer 4. Locating washer 5. Vacuum tire 120/90-12 6. Motor 7. Brake disc 8. Rear disc brake pump

Diameter of the rear brake disc:
 $\phi 180\text{mm}$

Thickness of the rear brake disc: 3.5mm
Operating limit: 2.5mm

Free travel of the brake handle:
7-15mm



Brake System

Maintenance instruction

Note

- There should be no oil stains on the brake assembly in installing or removal.
- The cleaning should be made with a specified detergent to avoid reduction of the brake performance.
- Oil stains on the brake pad will result in reduction of the brake performance
- Check the break before riding

Specifications

Item	Standard value (mm)	Minimum Thickness(mm)
Diameter of the front brake disc	φ220mm	-
Thickness of the front brake disc	4.0	3.0
Thickness of the front brake pad	4.0	3.0
brake fluid	DOT3 or DOT4	
Diameter of the rear brake disc	φ180mm	-
Thickness of the rear brake disc	3.5	2.5
Thickness of the rear brake pad	4.5	3.0
brake fluid	DOT3 or DOT4	

Torque value

Installation screws on the front/rear hydraulic brake disc	8	Nm
Tightening bolts on the Front Brake upper pump fixing screw	8	Nm



Failure diagnosis

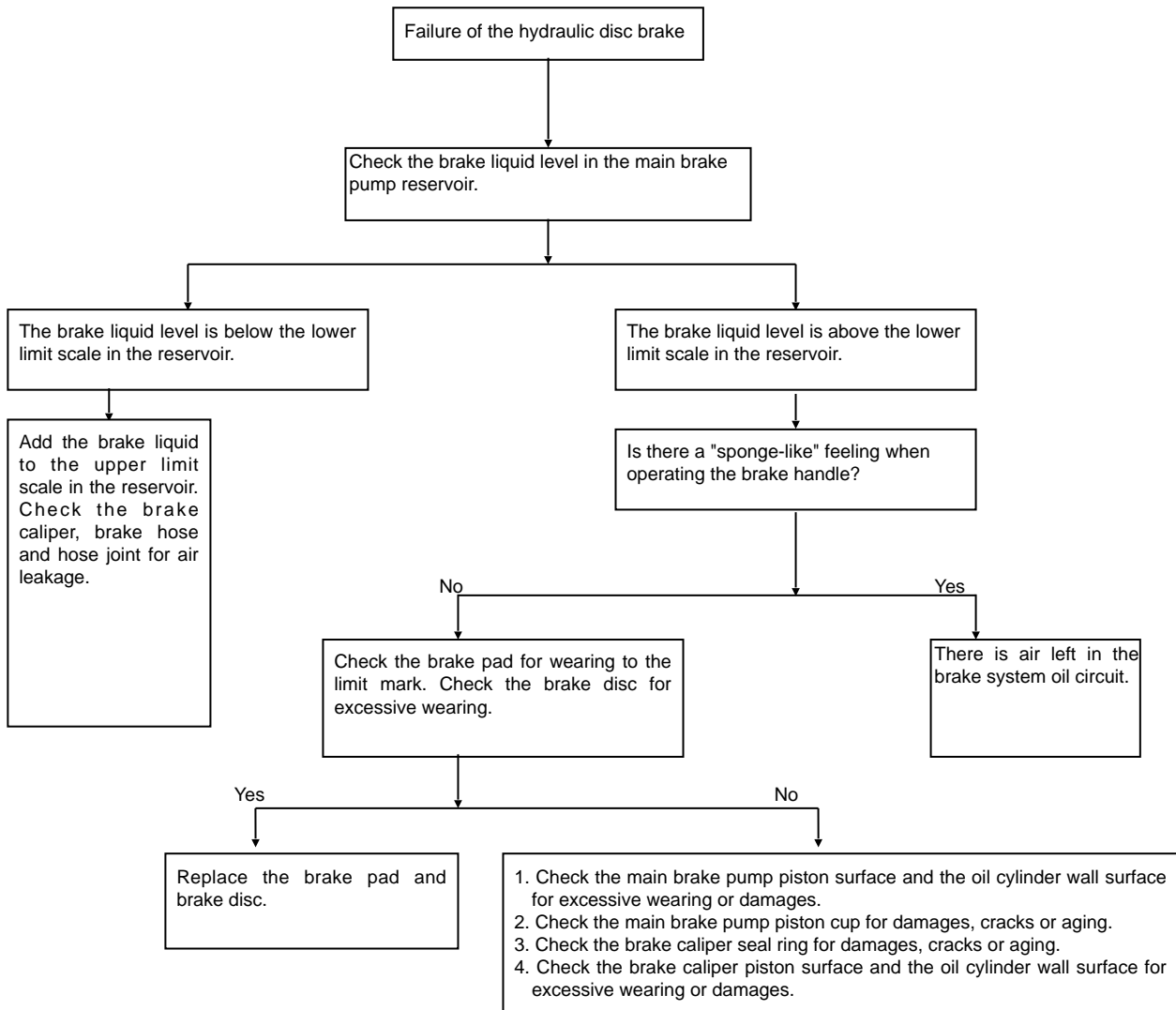



Failure diagnosis

The brake performance is not good.
The brake is not adjusted properly.
The brake pad and brake disc are worn.
The brake assembly is not installed properly.
The brake pad and brake disc are contaminated.
The brake responds slowly or the handle is tight.
The brake is not adjusted properly.
The brake pad and brake disc are worn.
The brake assembly is not installed properly.
There is an abnormal noise from the brake.
The brake pad and brake disc are worn.
The brake pad and brake disc are contaminated.
The brake handle is softened without an effective application.
There is air in the hydraulic system.
There is leakage from the hydraulic system.
The brake pad is worn.
The brake caliper piston seal is worn.
The main cylinder piston cup is worn.
The brake caliper is dirty.
The main cylinder is dirty.
The brake caliper does not slide smoothly.
The brake liquid level is low.
The flow channel is blocked.
The brake pad is bent and deformed.

Disassembling

Replace the brake pad assembly.
If the brake pad assembly will be used again, then it should be marked at side before removal so that it can be installed at its original position.
Remove the following assemblies from the handle and shock absorber.
Front/Rear brake:
1. Oil pump body assembly
2. Front/Rear brake disc
3. Brake cylinder assembly
4. Brake pad assembly
5. Brake hose assembly
6. Hydraulic brake handle

There should be no oil stains on the Front/Rear hydraulic brake pad assembly in installing or removal.
The cleaning should be made with a specified detergent to avoid reduction of the brake performance.
Loosen tightening bolts on the brake cylinder assembly.
Remove the brake cylinder assembly from the front shock absorber.
Remove the front axle, and remove the front wheel.
Remove the brake disc from the Front/Rear wheel.



Brake System

Brake liquid change/air discharging (for the disc brake type)

Drainage of the brake liquid

The paint coatings, plastics or rubber parts should be covered with cloths as good as possible to avoid splash of the brake liquid onto them in changing the system liquid or draining the liquid.

There should be no foreign matters that enter into the system in liquid injection into the liquid reservoir.

Turn the steering handle until the liquid reservoir on main oil cylinder becomes horizontal, before removal of the main oil cylinder cover.

Remove screws, oil cylinder cover and oil pan cover from the main oil cylinder on front brake.

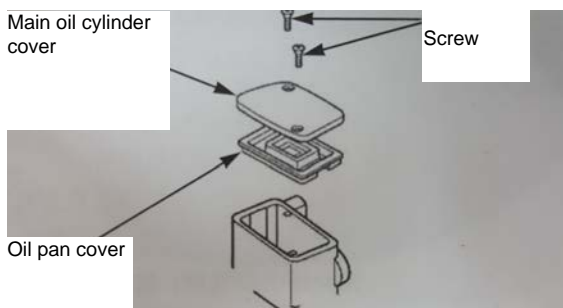

Connect the oil drainage hose to the oil drainage screw on front brake caliper.

Loosen the oil drainage screw and grasp the front brake handle tightly until the brake liquid does not flow out from the oil drainage screw.

Brake liquid injection/air discharging

Add the DOT3 or DOT4 brake liquid into the liquid reservoir, and add it to the upper limit of the liquid level.

Note:

Do not use different types of the brake liquid because they are not compatible with each other.

Connect air discharge pump from the brake liquid to the oil drainage valve screw.

Operate the air discharge pump from brake liquid, and loosen the oil drainage screw.

Check the brake liquid level frequently in air discharging to avoid air entrance into the hydraulic system.

Perform the discharging operation procedure strictly until the air discharging from hydraulic system is completed.

Seal thread of the oil drainage screw with a PTFE adhesive-tape, if the air can enter into the air discharge pump through the thread.

Tighten the oil drainage screw, and operate the brake handle. Repeat the air discharging operation if there is still a soft feeling.

Tighten the oil drainage screw on brake caliper after the air has been discharged completely.



Brake liquid injection/air discharging

The following operation steps can be performed if air discharge pumps are not available. Hold the front brake handle tightly and pressurize the system until there are no air bubbles from the liquid reservoir hole and the resistance to the front brake handle is felt.

Connect the oil drainage hose to the oil drainage screw, and perform air discharging from the system as per the following steps:

Check the brake liquid level frequently in air discharging to avoid air entrance into the hydraulic system. The brake handle should not be released before closure of the oil drainage screw.

Step1: Grasp the front brake handle for several times, and then hold the front brake handle at the same time to loosen the oil drainage screw to 1/2 circle. Wait for several seconds to tighten the oil drainage screw.

Step2: Loosen the front brake lever slowly until the front brake lever reaches to end of its travel. Wait for several seconds.

Step3: Repeat steps 1 and 2 until there are no air bubbles from the oil drainage hose.

Tighten the oil drainage screw on brake caliper after the air has been discharged completely. Add the DOT3 and DOT4 brake liquid that has been sealed completely into the liquid reservoir, and add it to the upper limit of the liquid level.

Install the oil pan cover and oil pan diaphragm. Tighten screws on the main oil cylinder.

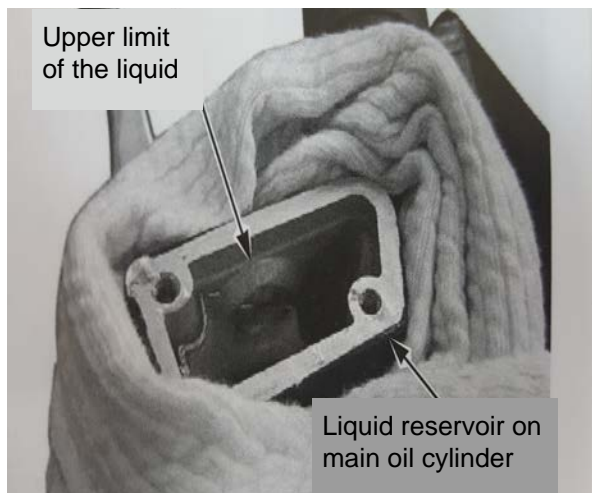



Lithium battery/charger

Overview

The charger will generate heat during charging. It should be subject to good ventilation and radiation.

The battery and charger must not be covered.

They must not be close to flammable or explosive objects in charging to avoid the explosion or fire that may cause personal injuries.

There is high-voltage current in the charger during charging. The charger is strictly prohibited from being opened in order to prevent electric shock.

The charging should be made indoors and should not be made at an open site in order to prevent the electric shorting or firing due to rain and other factors.

The charging process is strictly prohibited from being made in a rainy, exposure or high-temperature environment or close to fire sources.

Only original charger and a stable 110-240V AC power supply should be used in charging.

The polarity of the charger output connector must be consistent with the battery output connector, otherwise the charger and battery will be damaged.

Note

The Power Lock and Main Switch should be turned off before removal of electronic components.

The battery used for this model is a lithium battery.

Remove the battery from scooter storage for more than a week, Charge the battery to approximately 50% of its capacity and store it at a room temperature.

Perform periodical charging of the battery every month. The long-term storage of battery in below 20% of the electricity is strictly prohibited.

The battery should be fully charged for use after long-term storage.

The original battery for this model must be charged with the original charger that accompanies with the scooter (the scooter charging with a non-original charger will cause irrecoverable damages to the battery). Charging with a non-original charger may lead to the circuit or battery failure.

Battery charging is strictly prohibited from being made immediately after scooter stop. The charging should be made when the battery surface has been naturally cooled down (it is recommended to make charging after 30 minutes).

Stop charging immediately if the battery has not been fully charged for more than 24 hours and the red lamp does not turn to green, and then contact the after-sale service for inspection of the charger and battery.

Specification

Item		Specifications
Battery	Type	lithium battery pack
	Rated voltage	60V
	Rated capacity	20Ah~30Ah
Charger	Rated output voltage	71.4V
	Rated output current	3~4A



Battery Pack

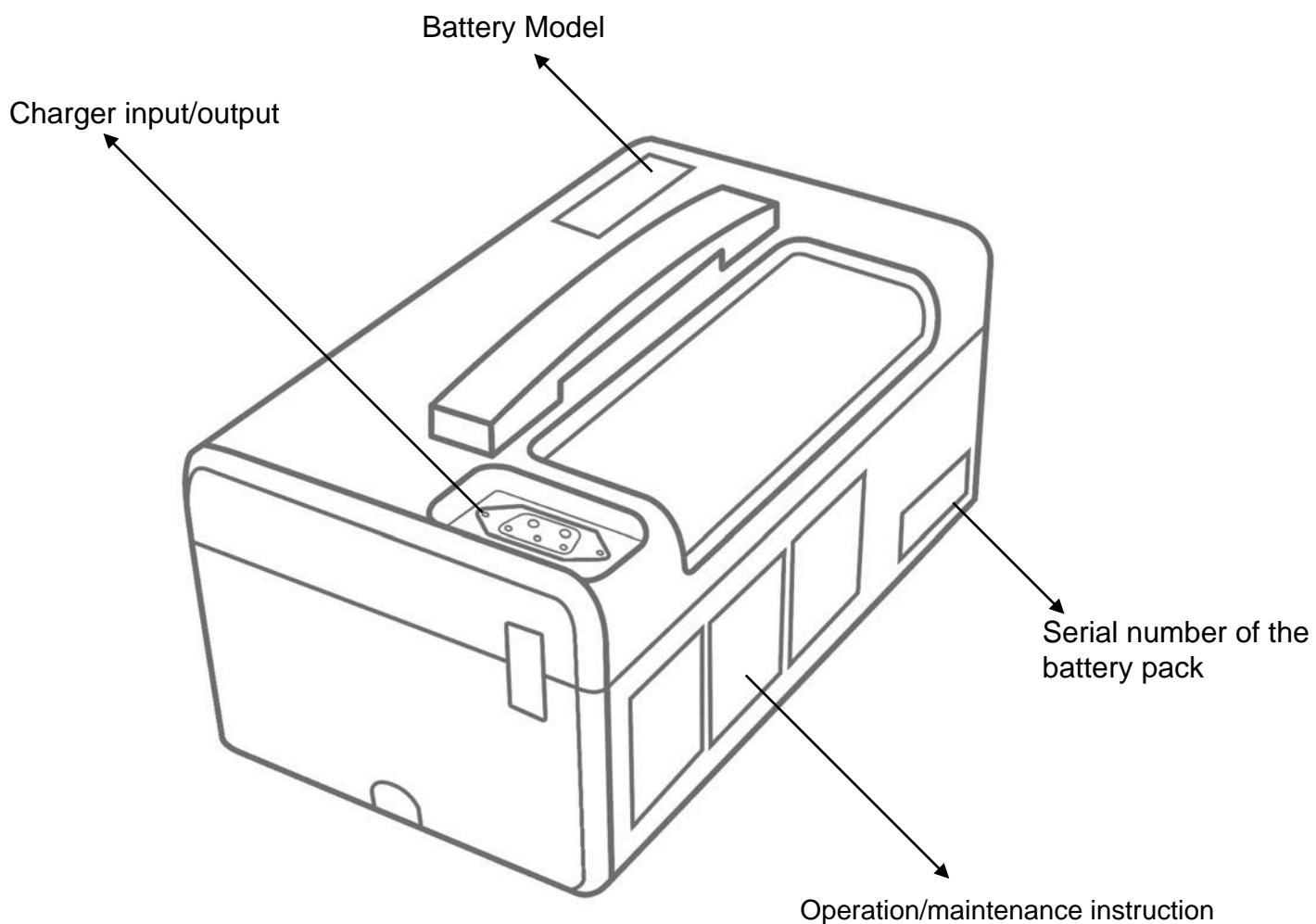



BMS (Battery Management System) Description

Connect H1 to Battery Pack directly, Press BMS_Info Icon to Read BMS Information

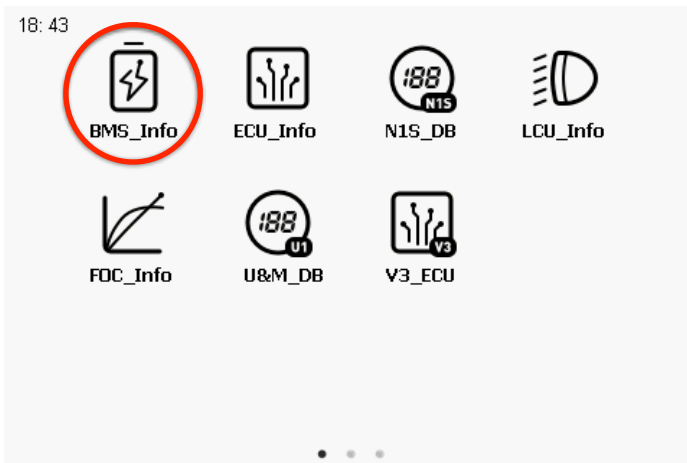

Please Make Sure The Power Is Turned OFF For More Than 10 Seconds
 You Can Also Connect H1 To Battery Pack Directly
 Press The Screen To Continue

Then press the screen to continue

If BMS is working normal/abnormal, H1 will read Battery Pack info shown as below.
 Replace the BMS if OFFLINE is shown.

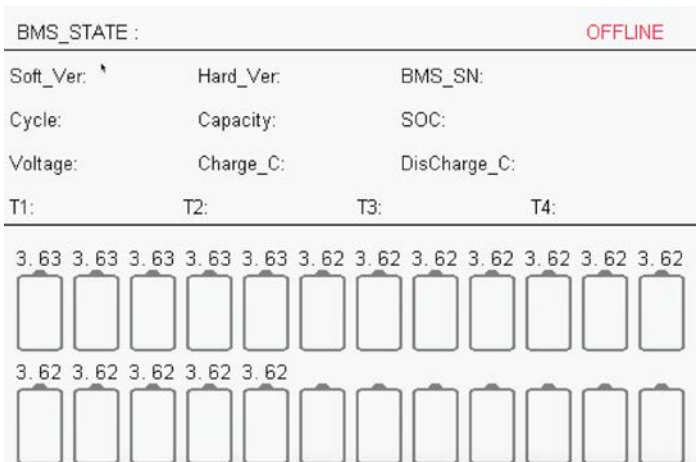
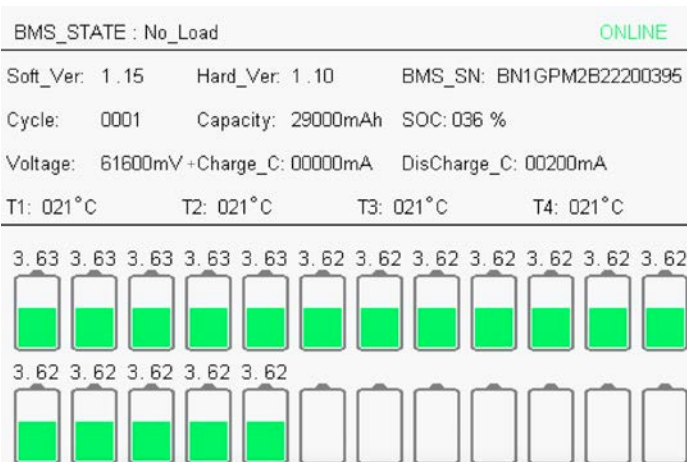

BMS_STATE: No Load
 ONLINE
 Soft_Ver: 1.15
 Har_Ver: 1.10
 BMS_SN: BN1GPM2B22200395
 Cycle: 0001
 Capacity: 29000mAh
 SOC: 036%
 Voltage: 61600mV
 Charge_C: 00000mA
 DisCharge_C: 00200mA
 T1: 021°C
 T2: 021°C
 T3: 021°C
 T4: 021°C
 Individual Battery Cell Voltages

BMS Status: currently not in use
 BMS Functioning, OFFLINE means BMS Failure,
 Replace BMS if necessary
 Software Version: 1.15
 Hardware Version: 1.10
 Battery Serial Number: BN1GPM2B22200395
 Number of Cycles Charged: 0001 Cycles
 Battery Total Capacity: 29Ah
 Remaining Battery Level: 36%
 Battery Total Voltage: 61.6V
 Charging Current: 0mAh
 Discharging Current: 200mAh
 Temperature Sensor 1: 21°C
 Temperature Sensor 2: 21°C
 Temperature Sensor 3: 21°C
 Temperature Sensor 4: 21°C
 Individual Battery Cell Voltages: 3.62V/3.63V



Table of BMS STATE(BMS Status)

No Load:
Discharging:
Charging:
Over-Charged:
Over-Discharged:
Charging Over-Current
Discharging Over-Current
Over Temperature
Temperature Low
Other Warning(Open Circuit detected/ Difference between Cell Voltages is higher than 0.3V)
Short Circuit
Water Detected
BMS MOS Failure

How to read Battery voltage (Ref 30)

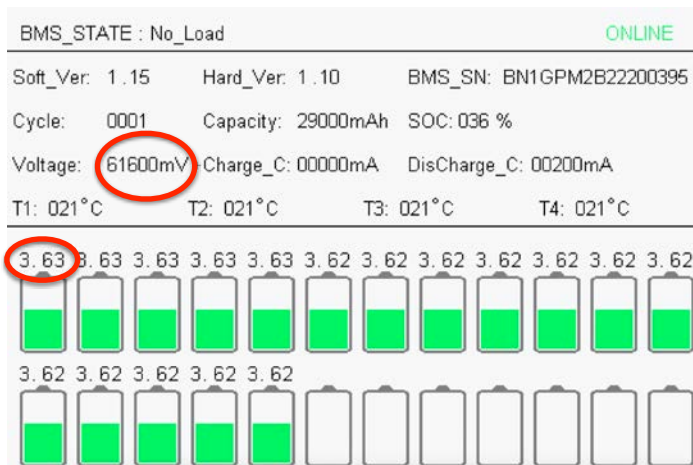

Connect H1 to Battery Pack directly, Press BMS_Info Icon to Read battery total voltage and single cell voltage

The max total voltage is 71.4V and max single cell voltage is 4.2V

The max voltage difference is 0.3V

The display will show code 30 (Battery overcharge) when the battery total voltage reached 71.4V or single cell reached 4.2V

Discharging warning code 131 will show on the display when the battery total voltage below 54.4V
BMS will enter protection state when the battery total voltage below 52.7V and single cell will be 3.1V (+- 0.1V)



Charger

When the charger is connected with battery. The indicator of charger illuminates as red means charging. It will turn to green when the battery is fully charged.

The charger should be disconnected first from the 110-240V AC power supply and then disconnect from the battery.





Electrical System

Main Harness diagram (01.2017~current)

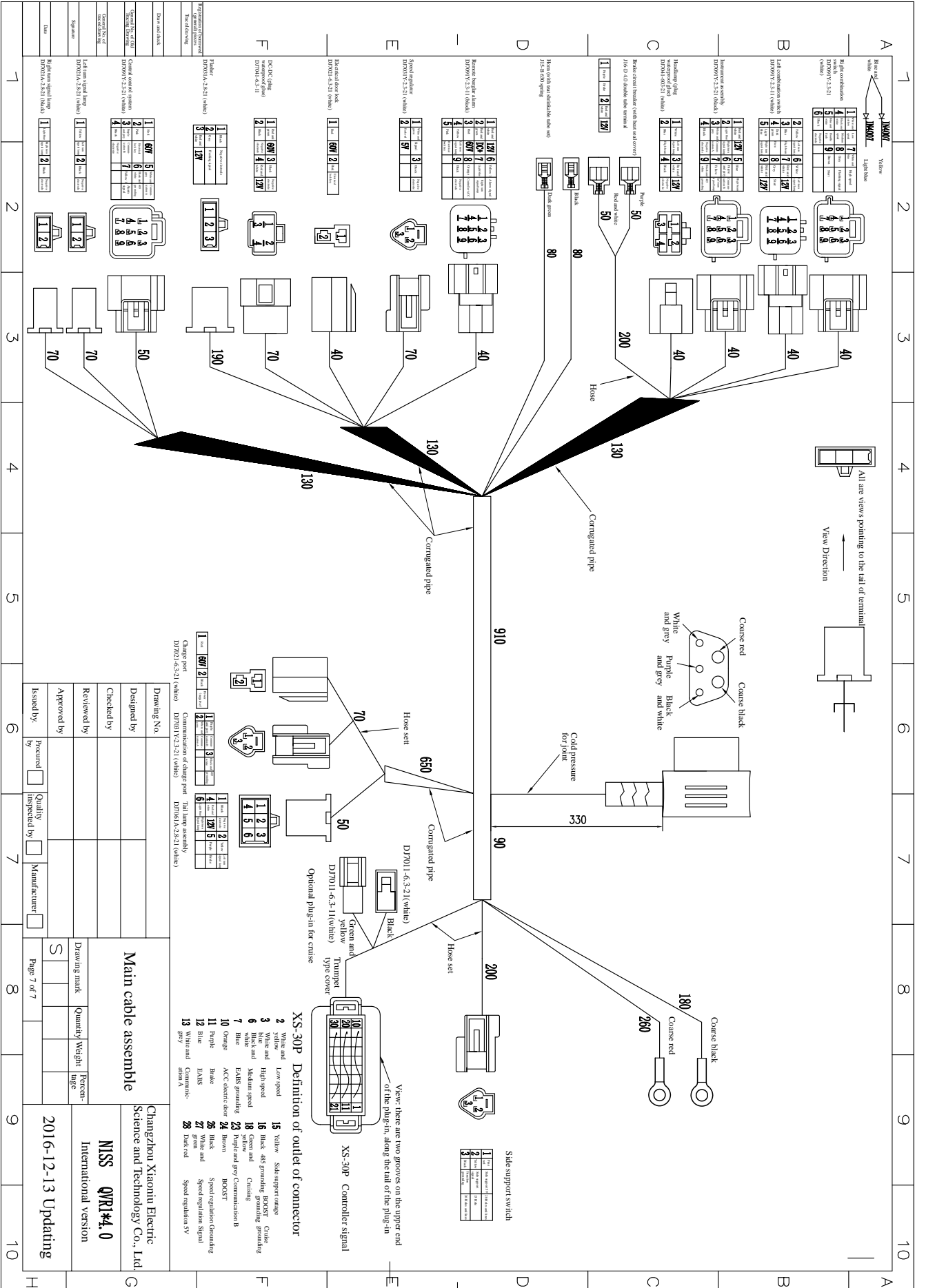



How to check Main Harness communication wire for closed circuit (Ref: 005)

Check communication between ECU and Battery

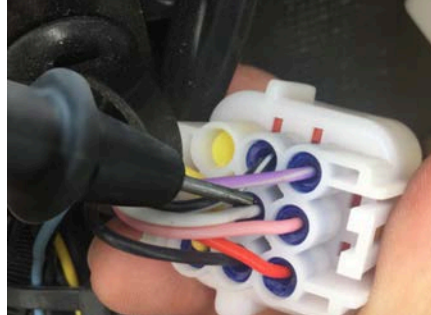

- Step 1: Disconnect the main Battery
- Step 2: Disconnect the ECU connector
- Step 3: Connect negative pin of multimeter to pin 5 (White) of ECU female connector
- Step 4: Connect positive pin of multimeter to the pin of power cord shown above(white and grey)
- Step 5: Set multimeter to test closed circuit mode which should beep if the circuit is closed.

Check communication between ECU and FOC controller

- Step 1: Disconnect the main Battery
- Step 2: Disconnect the ECU connector
- Step 3: Connect negative pin of multimeter to pin 3 (grey and violet) of ECU female connector
- Step 4: Connect positive pin of multimeter to the pin 23 of FOC controller connector(grey and violet)
- Step 5: Set multimeter to test closed circuit mode which should beep if the circuit is closed.





Check communication between ECU and Display

Step 1: Disconnect the main Battery

Step 2: Disconnect the ECU connector

Step 3: Connect negative pin of multimeter to pin 3 (grey and violet) of ECU female connector

Step 4: Connect positive pin of multimeter to the pin 6 of Display connector(grey and violet)

Step 5: Set multimeter to test closed circuit mode which should beep if the circuit is closed.





Electrical System

Circuit diagram (05.2016~current)

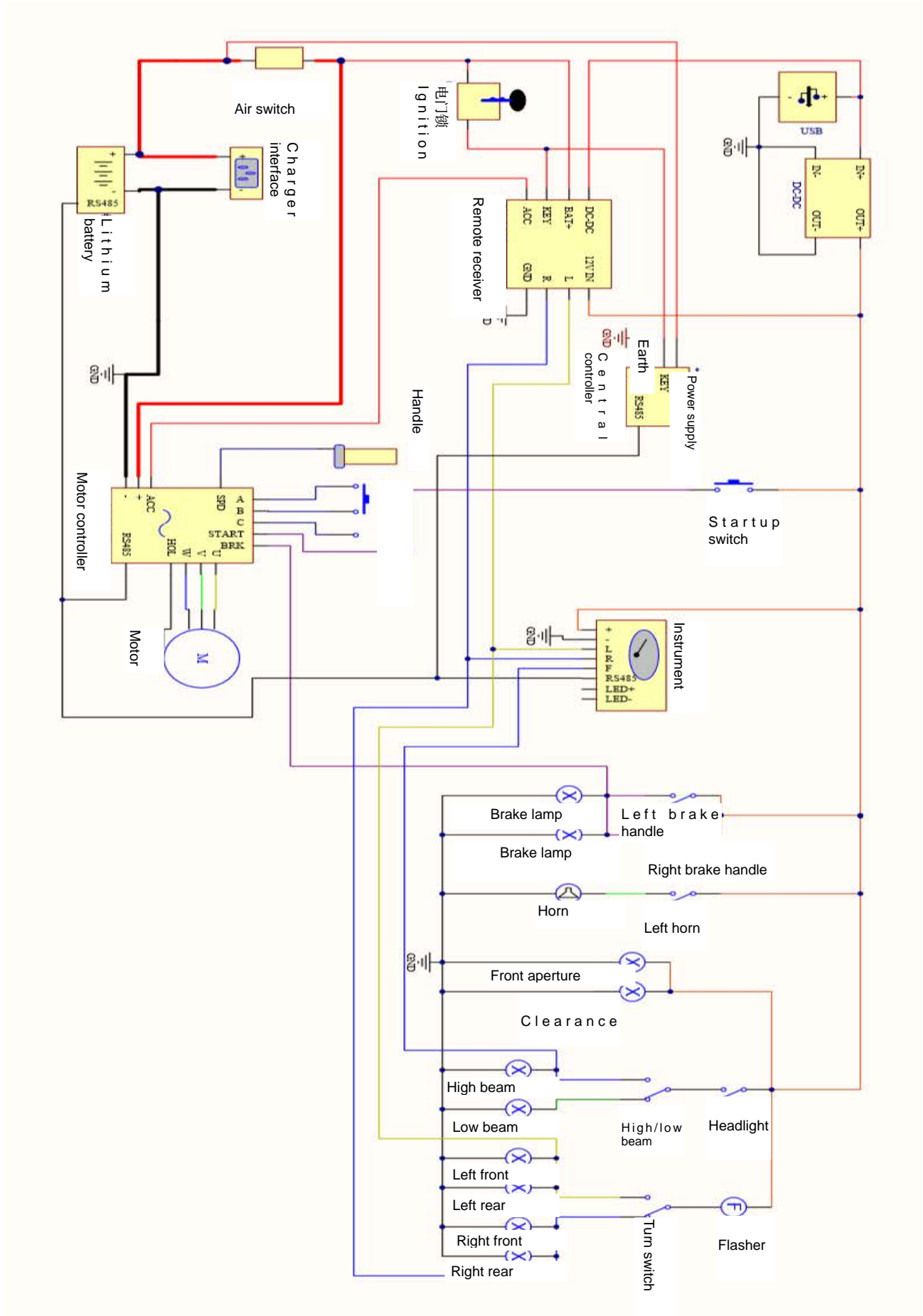



Electrical System

Motor

The motor used in this scooter is an efficient brushless DC motor with a permanent magnet made of rare earths, which is integrated with the rear wheel.

The motor does not require maintenance in daily riding. However, attention should be paid to the status of installation and tightening nuts on the motor shaft.

The motor is integrated with the rear wheel. Attention should be paid to inspection of the tire pressure during maintenance. Driving at insufficient tire pressure will cause damages to the motor hub.

The motor should be stopped immediately when the motor is abnormally hot, smoking, smelling abnormally, sounding abnormally or has other abnormal conditions.

Check the battery for normal performance and make it charged fully before maintenance of the motor system.

Check the Hall cable sensor connector, Hall motor connector and controller connector for shorting due to moisture, looseness or bad contact before maintenance of the motor system.

Attention should be paid to proper maintenance of the motor system and appropriate protection measures for avoidance of the electric shock, since the high current and voltage are involved.

The Hall cable sensor and Hall motor sensor should be inspected for shorting before replacement of the damaged controller with a new one, otherwise the new controller that has been installed will get damaged again.



The motor temperature rises higher and faster in a high-altitude area than in a plain area. Thus the scooter operating for a long time will easily result in the situation where the motor becomes abnormally hot and even the motor fails.

Pay attention to the wire polarity in installing the battery or controller.

Technical Specification

Item		Specifications
Motor	Motor type	Brushless permanent-magnet motor
	Control method	FOC vector control
	Rated voltage	DC60V
	Rated power	1500W
	Maximum motor power	2400w
	Maximum motor torque	120N*m
Controller	Rated voltage	DC60V
	Undervoltage protection	52±1V
	Maximum current of the controller	40A

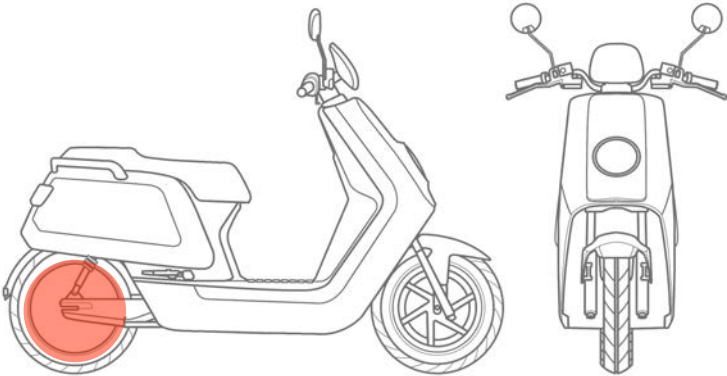

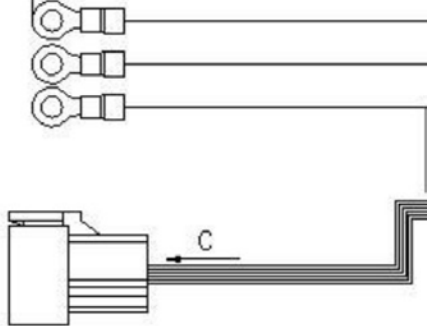
Component name	Motor	Connector code	J25-A
			
			
Connector Definition			
PIN	Color	Definition	
1	Blue	Phase	
2	Green	Phase	
3	Yellow	Phase	
Motor Hall			
1	Black	Power cord	
2	/		
3	Red	Phase	
4	Blue	Phase	
5	Green	Phase	
6	Yellow	Negative cord	
			



How to replace Motor (Ref: 009)

1. Screw up two hexagon flange bolts on the left and right side



2. Install the motor connectors on FOC controller



3. Connect the motor hall connector (Scooters produced before 2016 Dec)

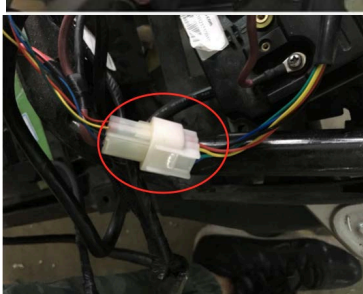



FOC Controller

The controller for this model makes controlling in the way that it receives the signal from speed regulation handle and controls operation of the brushless DC motor.

Main protective functions

1. Current limit protection

The maximum controller output current is limited to protect the motor, controller, battery and other components from being damaged by a current greater than specified.

2. Rotation failure (overload) protection

The controller judges the motor status automatically in a certain period of time after the motor rotation failure (over-current) occurs. It controls automatically the output current to protect safety of the motor, controller and battery.

3. Under-voltage/over-voltage protection

The controller stops automatically the motor rotation when the input voltage to motor is lower or higher than the set value, in order to protect safety of the motor and extend the battery lifetime.

4. Power cut-off protection in charging or braking

The controller stops the motor automatically to avoid unexpected injuries when the vehicle is being braked or charged.

5. Control loss protection

The controller stops the motor automatically to avoid unexpected injuries when the Hall cable sensor or its circuit fails and is out of control. The functions such as motor temperature protection, controller temperature protection and motor winding short protection are also provided.



Component Name	FOC Controller	Connector Code	J26-A																														
Connector Type		Connector 30P-J2X																															
																																	
Connector Definition																																	
PIN	Color	Definition																															
2	White and yellow	Mode 1																															
3	White and blue	Mode 2																															
6	White and black	Mode 3																															
7	Blue	EABS earth																															
10	Orange	ACC power lock																															
11	Violet	Brake lamp																															
12	Blue	EABS																															
13	White and grey	RS485(A)																															
15	Yellow	Side Stand Switch																															
16	Black	BOOST																															
	Black and white	Earth 485																															
	Black	Cruise earth																															
18	Green and yellow	Cruise																															
23	Violet and gray	RS485(B)																															
24	Brown	BOOST																															
26	Black	Handle (Twist grip) earth																															
27	White and green	Handle (Twist grip) signal																															
28	Dark red	Handle (Twist grip) 5V																															
 <table border="1" data-bbox="327 2011 662 2094"> <tr><td>10</td><td>9</td><td>8</td><td>7</td><td>6</td><td>5</td><td>4</td><td>3</td><td>2</td><td>1</td></tr> <tr><td>20</td><td>19</td><td>18</td><td>17</td><td>16</td><td>15</td><td>14</td><td>13</td><td>12</td><td>11</td></tr> <tr><td>30</td><td>29</td><td>28</td><td>27</td><td>26</td><td>25</td><td>24</td><td>23</td><td>22</td><td>21</td></tr> </table>		10	9	8	7	6	5	4	3	2	1	20	19	18	17	16	15	14	13	12	11	30	29	28	27	26	25	24	23	22	21		
10	9	8	7	6	5	4	3	2	1																								
20	19	18	17	16	15	14	13	12	11																								
30	29	28	27	26	25	24	23	22	21																								



How to read FOC controller indicator flashing frequency (Ref: 001)

- Turn ON the power and count how many times the indicator flashes between each interval.
- If FOC controller is in good working condition, after turning ON the power, the indicator should only flash once and no more flashing

FOC Controller Flashing Indicator Explanation			
Flashing Frequency	System protection feature		Solution
1	Over-Voltage warning	Battery voltage is higher than default value	
2	Under-Voltage warning	Battery voltage is lower than default value	
3	Over-Current warning	Instant current is higher than default value or Phase line short circuit	
4	Locked-rotor warning	Duration of Motor in locked-rotor status longer than default value	Replace FOC controller
5	HALL failure	Incorrect HALL input(Voltage) detected	Replace Motor
6	MOSFET failure	MOSFET power self-check failed	Replace FOC controller
7	Phase default warning	one or more of motor phase lines missing	Replace Motor
9	Brake applied	Controller in the braking status	
10	Self-checking failure	System on the internal electrical self-checking found abnormal	
11	Controller over-heat warning	Temperature is higher than default value	Stop riding until FOC controller cool down
14	Cable Hall Sensor Failure	Twist grip/Cable Hall Sensor Malfunction	
15	Alarm in active state	Alarm activated	
17	Communication failure	Communication between ECU and FOC controller failed	Replace FOC controller



How to check FOC Controller power input (Ref: 013)

Step 1: Turn the power OFF.

Step 2: Check voltage of the main power cord by disconnecting the following connectors:

- Controller connector
- Red and Black wires

Step 3: Check DC voltage between the Red wire and Black (Negative) at harness side.

Step 4: Turn the power ON and DC voltage reading on multimeter should be same as battery voltage.





How to check FOC controller ACC wire of Alarm for closed circuit (Ref: 007)

Step 1: Turn the power ON.

Step 2: Check voltage of the PIN 10 orange (ACC power lock) by disconnecting the following connectors:

- Controller connector
- Red and Black wires

Step 3: Check DC voltage between the PIN 10 orange (ACC power lock) and Black (Negative) at harness side.

Step 4: Turn the power ON and DC voltage reading on multimeter should be same as battery voltage.







How to replace FOC controller (Ref: 004)



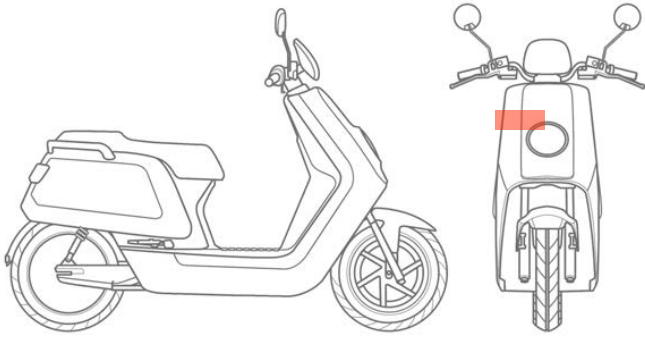

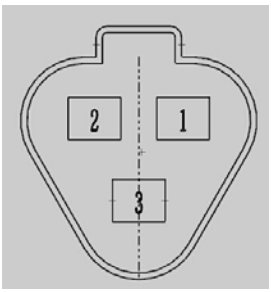
Component Name	Cable Hall Sensor	Connector Code	J25-A
Connector Type			
			
Connector Definition			
PIN	Color	Definition	
1	Dark red	Power cord	
2	White and green	Signal wire	
3	Black	Negative electrode	
			



How to adjust Twist Grip (Ref: 010)



Tighten the adjuster.
Free travel distance 2-4mm



Loosen the adjuster.
Free travel distance 2-4mm



How to check Hall Cable Sensor (Ref: 011)

Inspection of the signal output

Turn the power lock switch to OFF.

Remove the front panel.

Connect the multimeter between the white/green signal output wire and the black ground wire on Hall cable sensor.

Turn the ignition switch to ON. Turn the handle slowly from the start angle to the end angle, and check the signal output voltage between them.



Connection: White/green (+) - black (-)

Standard: Start angle 0.83 - 0.9V

End angle 3.75 - 3.85V

The voltage should change smoothly between standard values with turning Twist Grip.

How to check Cable Hall Sensor power input (Ref: 014)

Turn the ignition switch to OFF.

Disconnect the Hall cable sensor connector.

Turn the ignition switch to ON.

Check the voltage between the dark red wire and the black wire.

Connection: Dark red (+) - black (-)

Standard: 4.2V-5V

Check the following items if the measurement value is far more than the standard one:

- The controller failed
- The circuit between controller and Hall cable sensor is in a bad contact or is open.



How to replace Hall Cable Sensor (Ref: 012)

1. Pull out the cable of twist grip



2. Unscrew the four screws as guide picture





3. Disconnect the connector of Hall Cable Sensor



4. Reassemble Hall Cable Sensor is reverse order

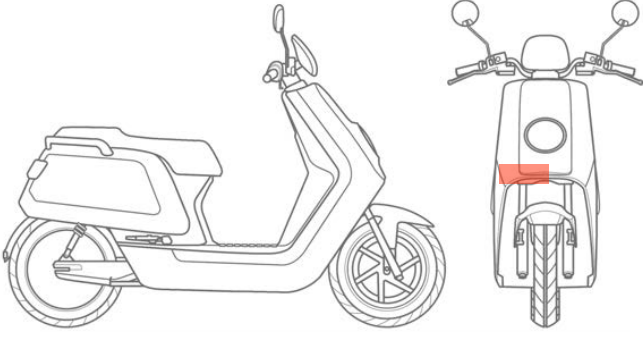

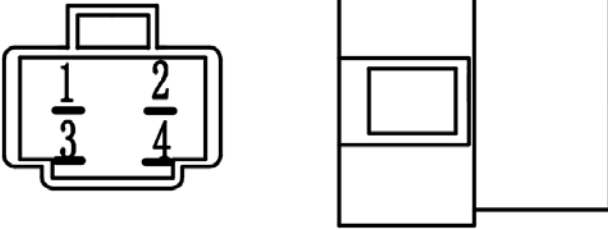
Component Name	DC-DC Converter	Connector Type	
			
Connector Code	J12-A		
PIN	Color	Definition	
1	Red and green	60V input wire to the converter	
2	Black	Negative electrode	
3	Black	Negative electrode	
4	Red and white	Power cord (12V)	
			



How to check DC-DC Converter power input (Ref: 015)

Step 1: Turn the power ON.

Step 2: Check DC voltage between the Red wire and Black (Negative) at component side.

Step 3: DC voltage reading on multimeter should be same as battery voltage.



How to check DC-DC Converter power output (Ref: 016)



Step 1: Turn the power ON.

Step 2: Check DC voltage between the Yellow and Black (Negative) at component side.

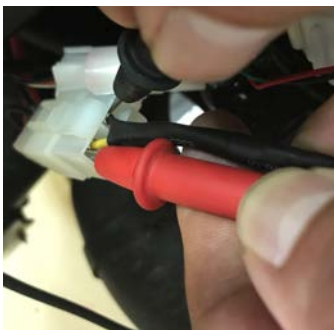
Step 3: DC voltage reading on multimeter should be ~12V



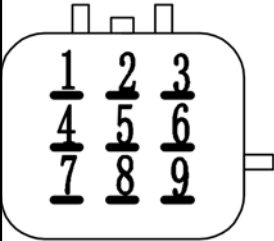
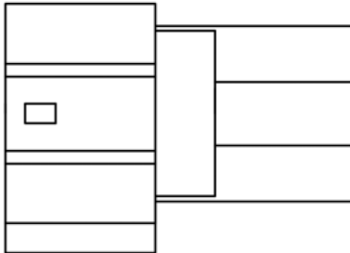

Component Name	Alarm	Connector Type	
			
Connector Code	J3-A		
PIN	Color	Definition	
1	Red and white	Power cord (12V)	
2	Red and green	DC+	
3	Red	Power cord (60V)	
4	Yellow	Left turn signal lamp wire	
5	Pink	Power Lock	
6	Yellow 1	Alarm signal	
7	Light blue	Right turn signal lamp wire	
8	Orange	Controller ACC	
9	Black	Negative electrode	
			

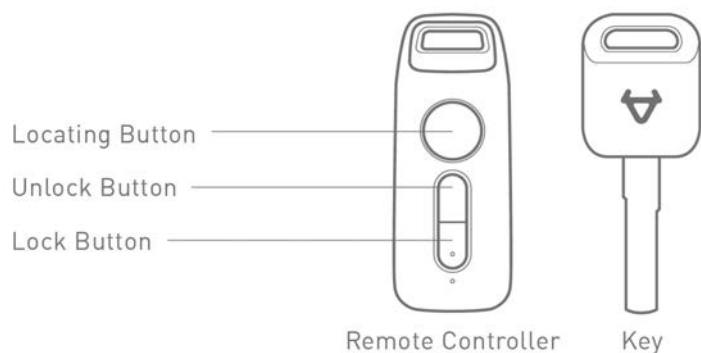



How to check Alarm (Ref: 017)

Step 1: Press buttons of the remote, the indicator should light up, if not, use the backup remote or Check the remote battery

Step 2: if the horn doesn't work after pressing the remote buttons, then replace the alarm

Step 3: if both horn and lights works after pressing remote buttons, then check alarm voltage input/output

Step 4: Use a multimeter and set to DC, measure alarm voltage input(Negative to Black wire, Positive to Red wire), should get result equal to battery voltage.



Step 5: measure voltage output to DC-DC(Negative to Black wire, Positive to Red/Green wire), should get result equal to battery voltage, if not, replace the alarm

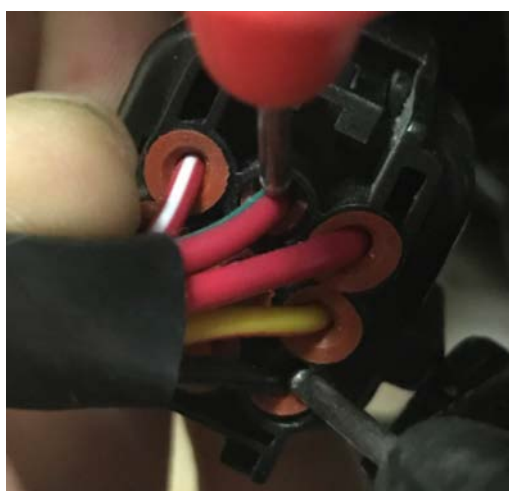

How to adjust Alarm sensitivity (Ref: 018)

Press LOCATING button and hold until start beeping(once is least sensitive and 5times is most sensitive),

release your finger to select sensitive setting



How to replace Alarm (Ref: 008)

1. Unscrew the two screws as guide picture





3. Disconnect the connector of Alarm



3. Reassemble Alarm is reverse order

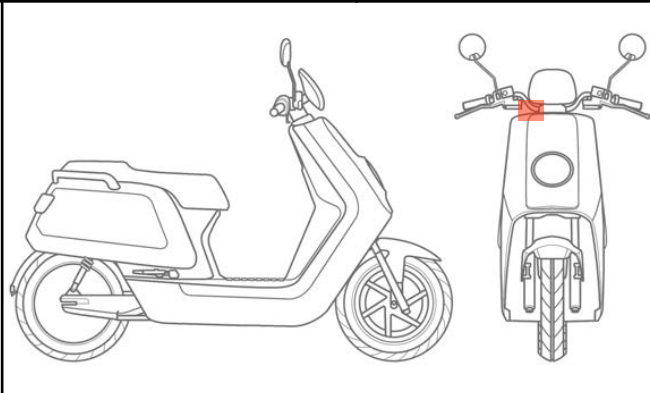

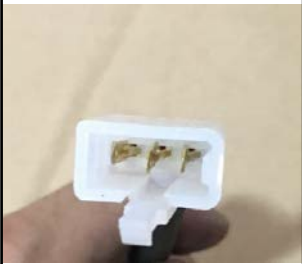
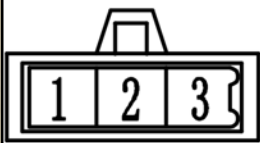
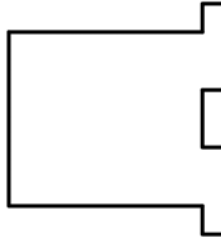
Component Name	Flasher	Connector Code	J14-A
			
PIN	Color	Definition	
1	Black	Negative electrode	
2	Grey	Flashing signal	
3	Red and white	Power cord (12V)	
			



How to check Flasher (Ref: 019)

Remove the front panel.

The flashing relay is above the alarm

Check the following items:

- Functions of the ignition switch and turn signal switch
- Connector looseness

Disconnect the turn signal relay connector from the relay.

Make the turn signal relay connector terminal (at cable side) shorted with a short wire.

Turn the power lock switch to ON. Check the turn signal lamp.

The signal lamp that illuminates indicates that the turn signal relay failed.

The lamp that does not illuminate indicates that the harness is broken.

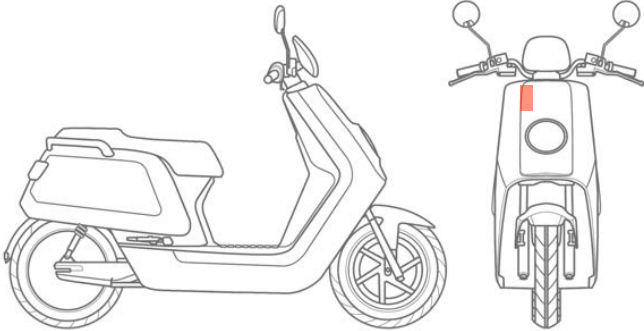
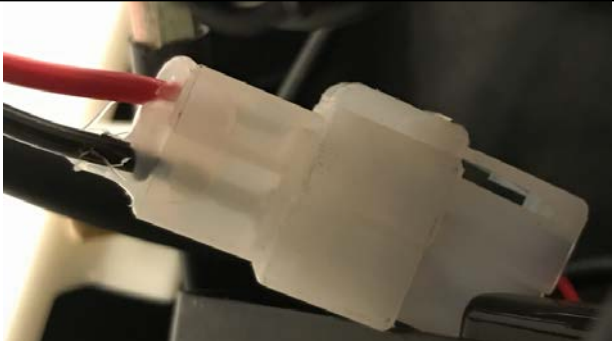
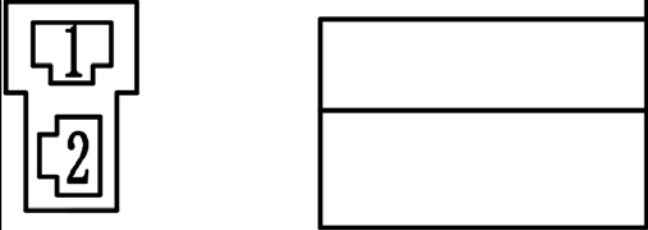

Component Name	Power Lock	Connector Code	J11-A
Connector Type			
			
Connector Code	J11-A	Component side	
PIN	Color	Definition	
1	Red	Power cord (60V)	
2	Black	Power Lock On/Off	
Connector Code	J11-B	Harness side	
PIN	Color	Definition	
1	Red	Power cord (60V)	
2	Pink	Electrical lock key	
			

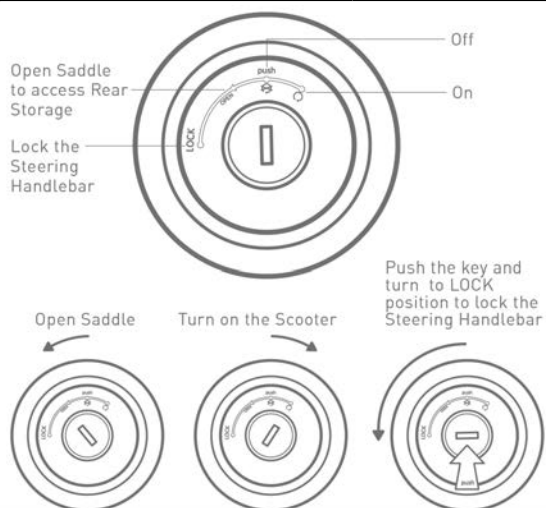



How to check Power Lock (Ref: 020)



Step 1: Turn the power ON

Step 2: Check DC voltage between Pink wire and Red wire

Step 3: DC voltage reading on multimeter should be same as battery voltage



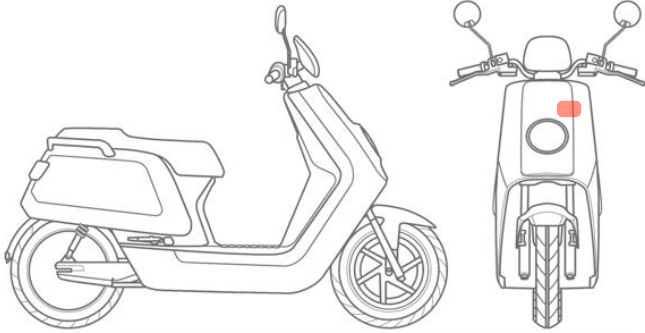
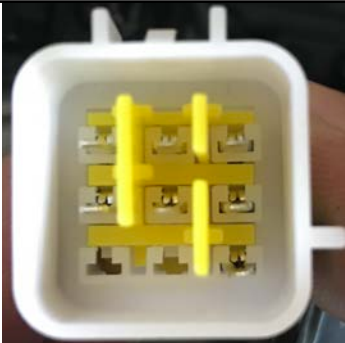

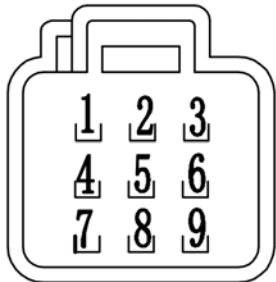
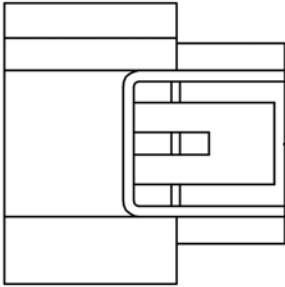
Component Name	ECU	Connector Code	J2-A
Connector Type			
			
Disassembling			
Connector Definition			
PIN	Color	Definition	
1	Red	Power cord(60V)	
2	Pink	Power Lock On/Off	
3	Violet and Grey	Communication B	
4	Black	Negative electrode	
5	White and Grey	Communication A	
6	Black and white	485 Ground wire	
7	Yellow 1	Alarm signal	
8	/		
9	/		
			
			
			



How to check ECU by checking App Data (Ref: 002)

- This method only applied to scooter with activated SIM card
- Log into NIU E-scooter App to check latest data update, replace ECU if data is not up to date

How to replace ECU (Ref: 003)

1. Disconnect the Battery



2. Remove two Front Glove Compartment Bolt Hole Plugs and unscrew two screws inside



3. Remove Front Neck Cover by lifting it at front



4. Unscrew two screws on the top of Front Panel





5. Take out two Plastic Expansion Clips from the bottom of Front Panel



6. Remove Front Panel by pushing it upward



7. Unscrew four screws on Smart Central Controller



8. Deattach the connector of Smart Central Controller and replace a new one

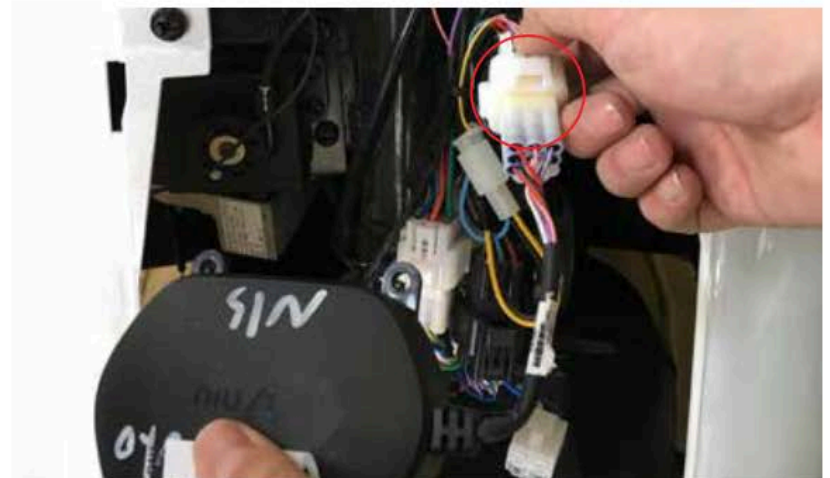



Bound NIU E-scooter APP

Step 1: Use a smart phone to scan the QR code of the spare part ECU



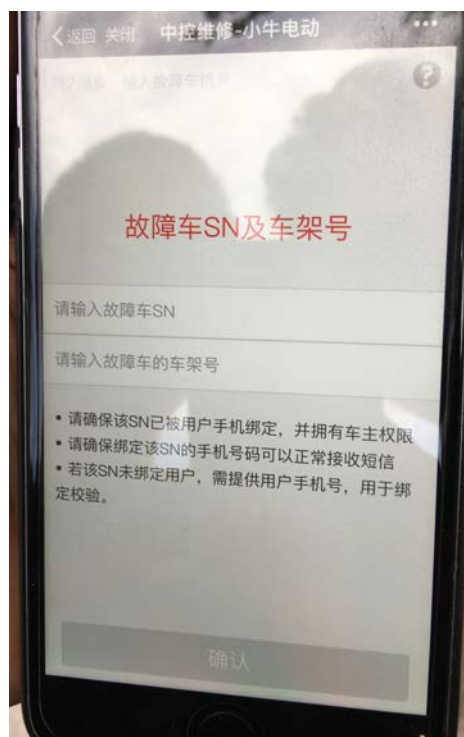
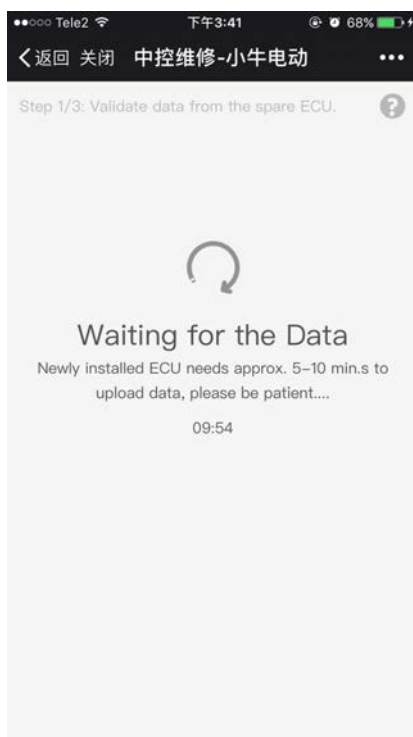

Step 2: Input details of the vehicle which the spare part ECU is about to be installed, information such as Vehicle Frame Number, Vehicle SN and mobile number which was banned on the App.



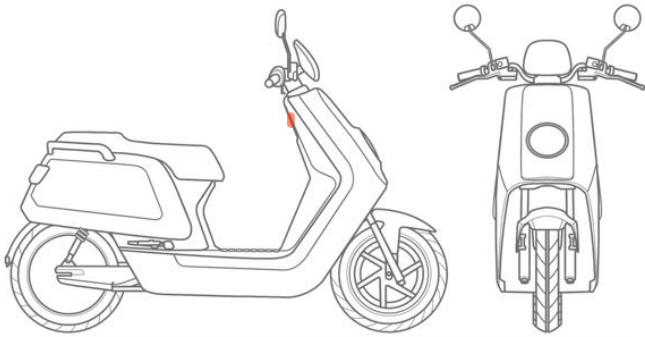
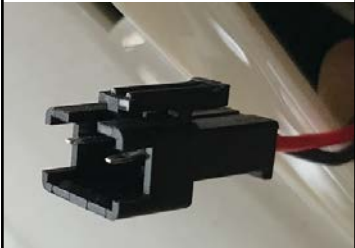

Step 3: Check App status after 24 hours or contact activation.help@niu.com for help.

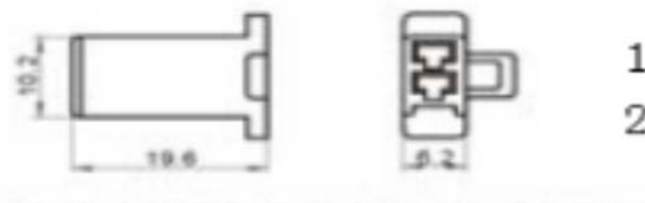

Component Name	USB	Connector Code	J5-A
Connector Type			
			
Disassembling			
Connector Definition			
PIN	Color	Definition	
1	Red	Power cord (60V)	
2	Black	Negative electrode	
			

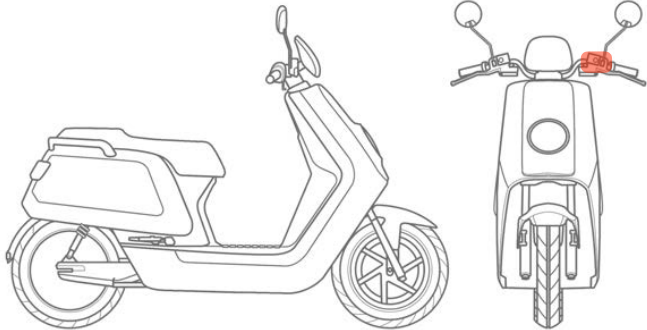
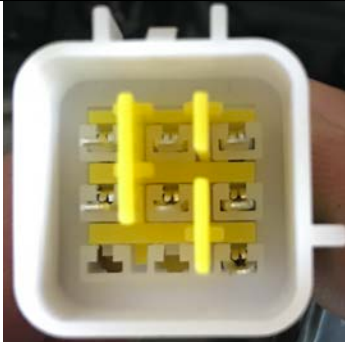

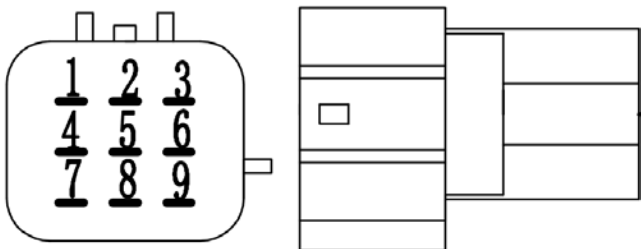
Component Name	Left combination switch	Connector Code	J1-A
Connector Type			
			
Disassembling			
Connector Definition			
PIN	Color	Definition	
1	/		
2	Yellow	Left turn signal lamp	
3	Blue	High beam	
4	Dark green	Horn	
5	Light blue	Right turn signal lamp	
6	White	Low beam	
7	Red and white	Power cord (12V)	
8	Grey	Flashing	
9	Red and white	Power cord (12V)	
 			

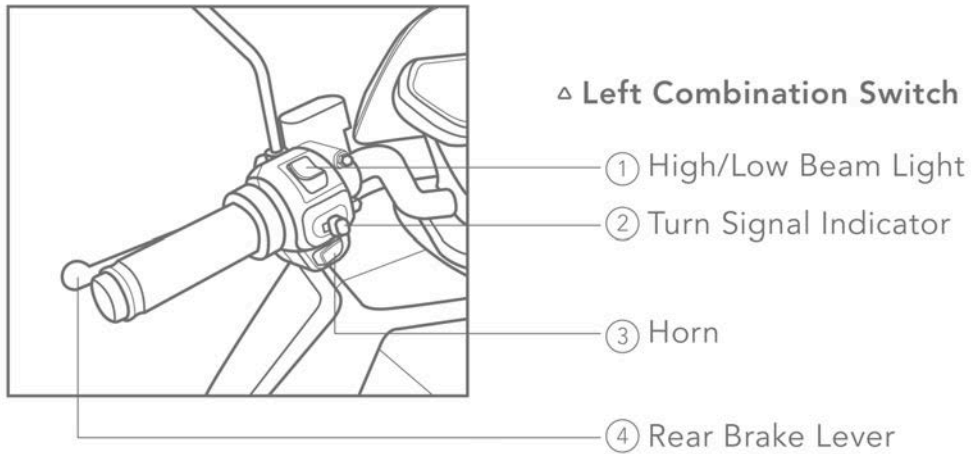

How to check Left Combination Switch (Ref: 022)

Check the Left turn signal

Step 1: Turn the power ON

Step 2: Check DC voltage between Yellow wire (Left turn signal) and Black wire of another connector

Step 3: DC voltage reading on multimeter should be around 12V when the corresponding switch is on

Other switch detection methods are the similar, choose the corresponding wire and check DC voltage





Component Name	Right combination switch	Connector Code	J2-A
Connector Type			
Disassembling			
Connector Definition			
PIN	Color	Definition	
1	White and yellow	Mode 1	
2	/		
3	/		
4	White and black	Mode 2	
5	Blue and white	Hazard	
6	Black	Negative electrode	
7	Blue and white	Mode 3	
8	Grey	Flasher Signal	
9	Brown	Startup button	

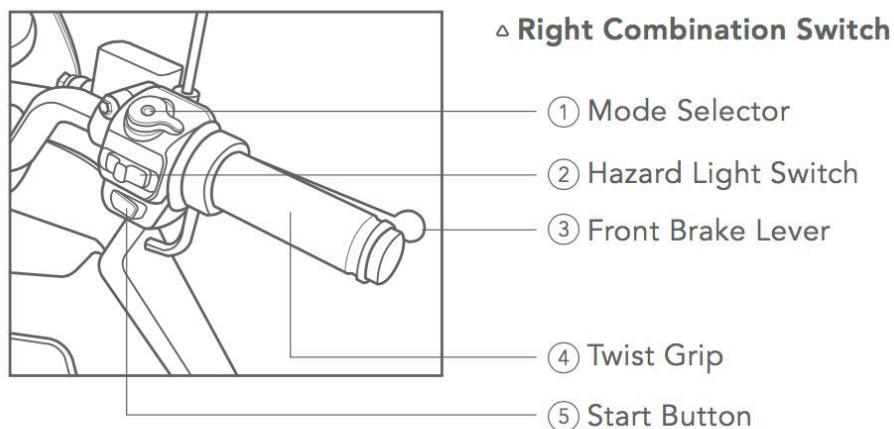

How to check Right Combination Switch (Ref: 021)

Check the Hazard Light Switch



Step 1: Turn the power ON

Step 2: Check DC voltage between pin 5 blue wire (Hazard) and Black wire of another connector

Step 3: DC voltage reading on multimeter should be around 12V when the corresponding switch is on

Other switch detection methods are the similar, choose the corresponding wire and check DC voltage

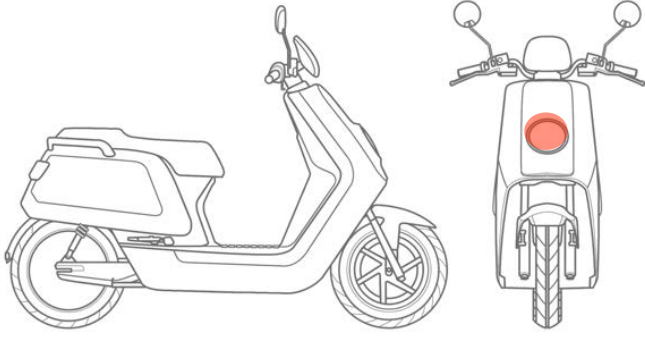

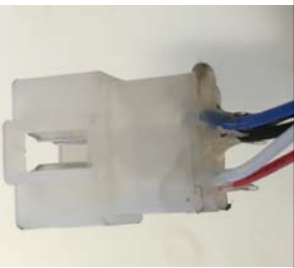
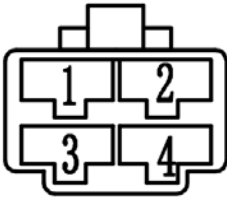
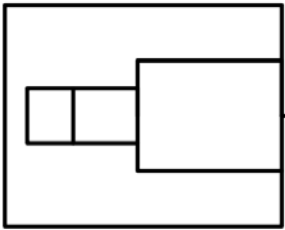
Component Name	Headlight	Connector Code	J13-A
Connector Type			
			
Disassembling			
Connector Definition			
PIN	Color	Definition	
1	White	Low beam	
2	Blue	High beam	
3	Red and white	Power cord (12V)	
4	Black	Negative electrode	
			



How to check Headlight (Ref: 023)









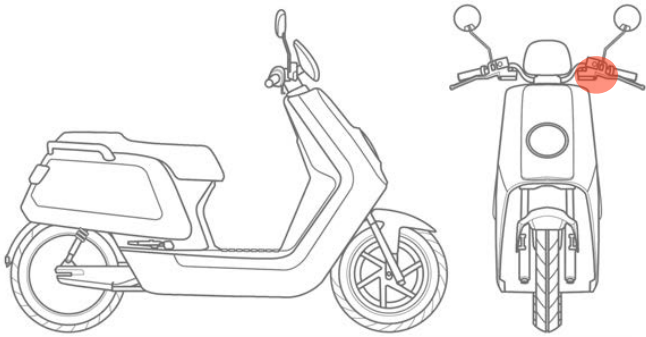

Step 1: Turn the power ON

Step 2: Check DC voltage between Red-White wire and Black wire

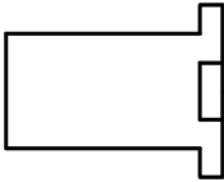
Step 3: DC voltage reading on multimeter should be ~12V

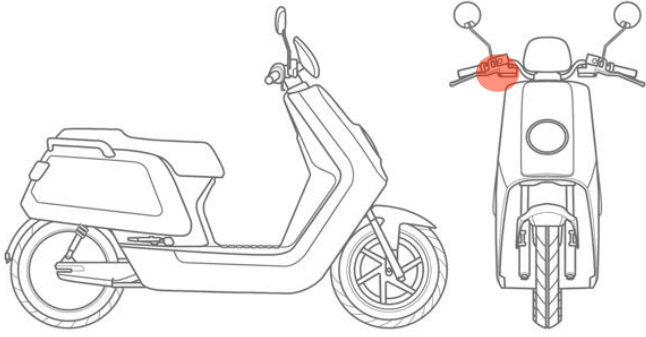

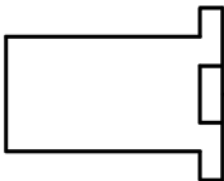

Component Name	Left turn signal lamp	Connector Code	J7-A	
Connector Type				
				
Disassembling				
Connector Definition				
PIN	Color	Definition		
1	Yellow	Left turn signal lamp		
2	Black	Negative electrode		
				
Component Name	Right turn signal lamp	Connector Code	J8-A	
Connector Type				
				
Disassembling				
Connector Definition				
PIN	Color	Definition		
1	Light blue	Right turn signal lamp		
2	Black	Negative electrode		
				



How to check Left turn signal lamp (Ref: 024)

Step 1: Turn the power ON

Step 2: Check DC voltage between Yellow wire and Black wire on component side

Step 3: DC voltage reading on multimeter should be ~12V



How to check Left turn signal lamp (Ref: 025)

Step 1: Turn the power ON

Step 2: Check DC voltage between Yellow wire and Black wire on component side

Step 3: DC voltage reading on multimeter should be ~12V



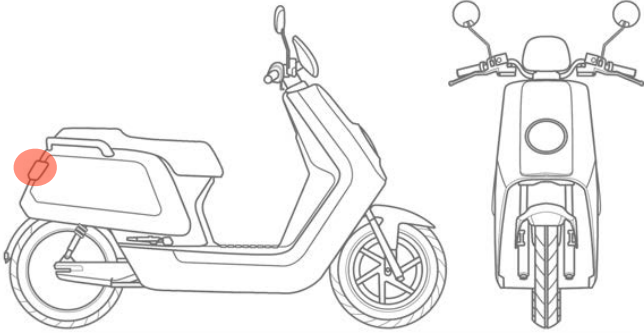
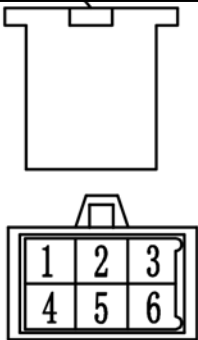

Component Name	Tail Light	Connector Code	J9-A
Connector Type			
			
Disassembling			
Connector Definition			
PIN	Color	Definition	
1	Black	Negative electrode	
2	Yellow	Left lamp signal wire	
3	/		
4	Red and white	Power cord (12V)	
5	Violet	Brake lamp	
6	Light blue	Right lamp signal wire	
			



How to check Tail Light (Ref: 026)







Step 1: Turn the power ON

Step 2: Check DC voltage between Yellow wire and Black wire on component side

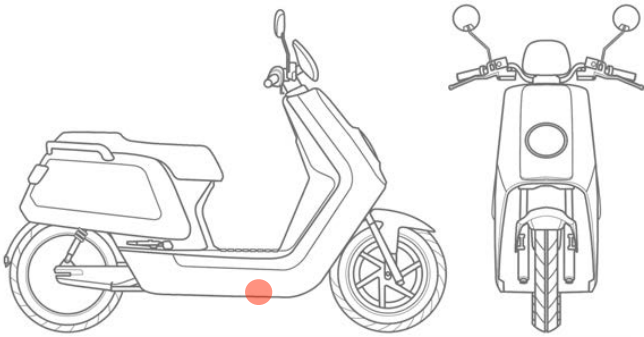
Step 3: DC voltage reading on multimeter should be ~12V

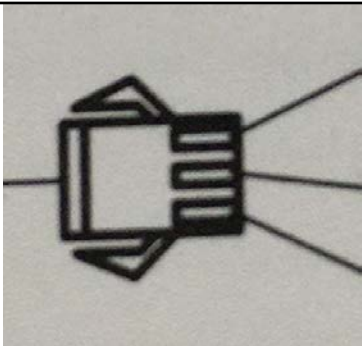

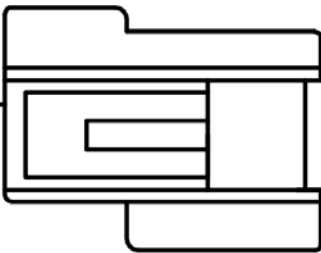

Component Name	Side Stand Switch	Connector Code	
Connector Type			
			
Disassembling			
Connector Definition			
PIN	Color	Definition	
1	Red	Power cord (5V)	
2	Yellow	Side Stand Switch signal	
3	Black	Negative electrode	
			
			



How to check Side Stand Switch (Ref: 027)



Step 1: Turn the power ON

Step 2: Check DC voltage between Yellow wire and Black wire on component side



Step 3: DC voltage reading on multimeter should be $\sim 3.75\text{V}$ when side stand is not applied, and should be $\sim 5\text{V}$ when side stand is applied

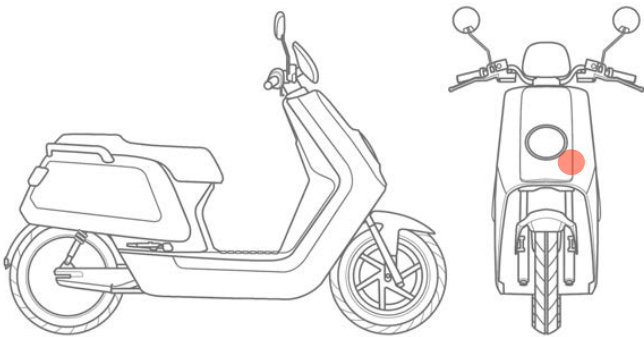

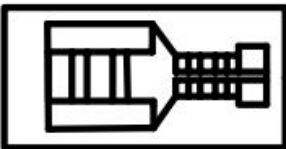
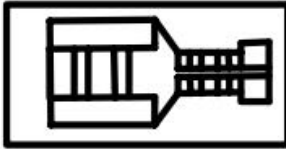

Component Name	Horn	Connector Code	
Connector Type			
			
Disassembling			
Connector Definition			
PIN	Color	Definition	
1	Green	Horn	
2	Black	Negative electrode	
		 <p style="text-align: right;">Black</p>  <p style="text-align: right;">Dark green</p>	

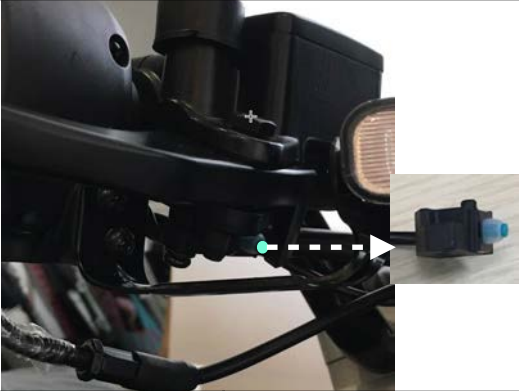
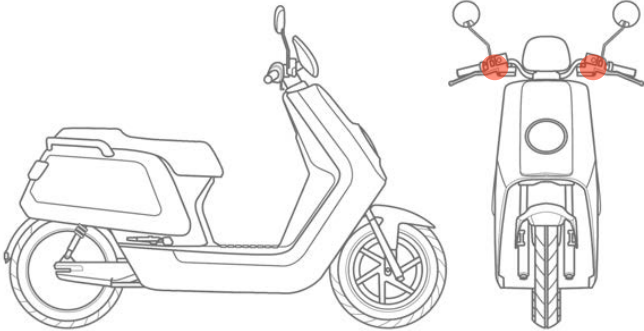

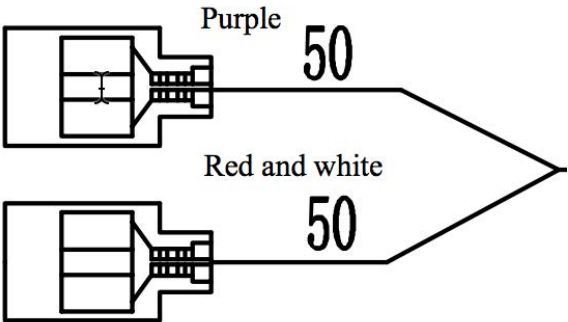
Component Name	Left/right brake Switch	Connector Code	J16-B
Connector Type			
			
Disassembling	4.0 dual-cylinder insertion spring		
Connector Definition			
PIN	Color	Definition	
1	Red and White	Power cord(12V)	
2	Violet	Left/right brake handle signal wire	
			



How to check Brake Switch (Ref: 028)

Step 1: Check Brake Switch for close circuit by disconnecting the Brake Switch connectors

Step 2: Set multimeter to test closed circuit mode which should beep in brake state shown as picture on the right.

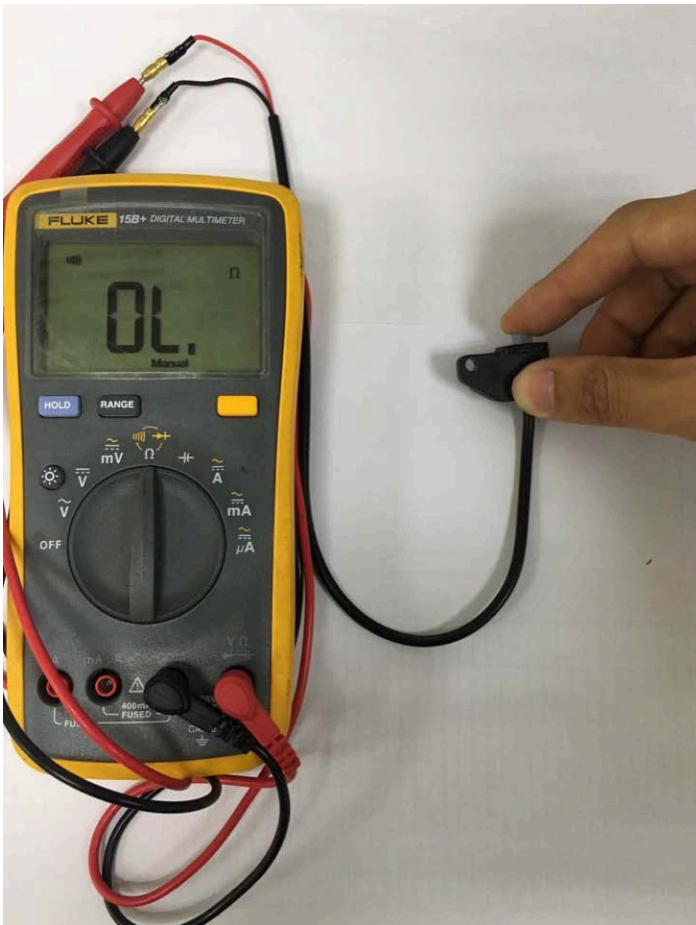

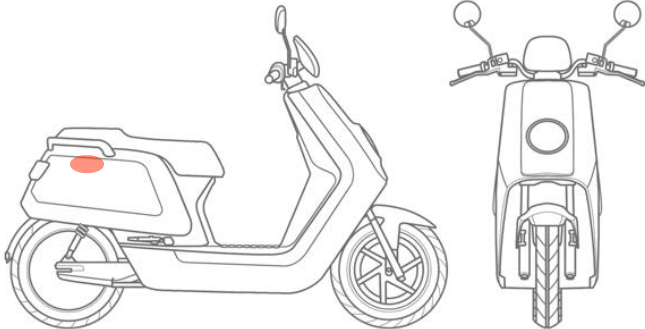
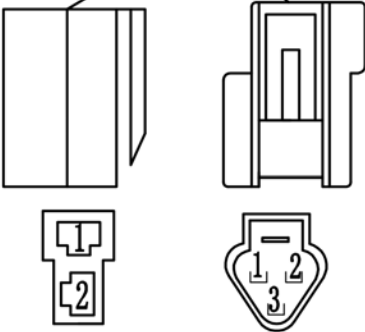

Component Name	Charging Port	Connector Code	J10-A
Connector Type			
			
Disassembling	4.0 dual-cylinder insertion spring		
Connector Definition			
PIN	Color	Definition	
1	Red	Power cord (60V)	
2	Black	Negative electrode	
1	Purple and Grey	Communication B	
2	White and Grey	Communication A	
3	Black and White	485 Earth	
			



How to check Charging Port (Ref: 029)



Step 1: Remove the Under Seat Storage Compartment and find the charging port connector

Step 2: Check DC voltage between Red wire and Black wire on component side

Step 3: DC voltage reading on multimeter should be same as the Charger output voltage



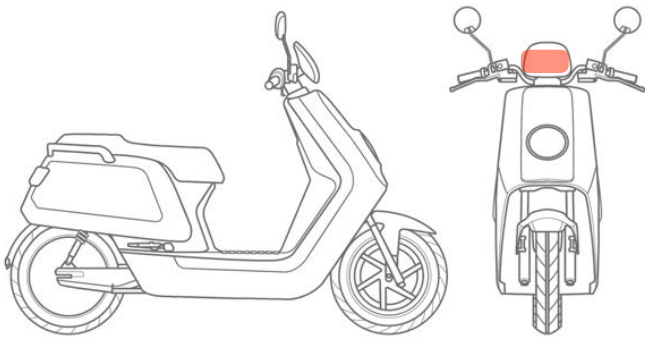

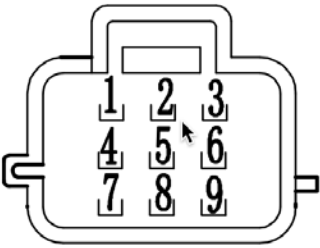
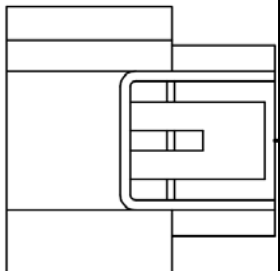
Component Name	Display	Connector Code	J6-A
Connector Type			
			
Disassembling			
Connector Definition			
PIN	Color	Definition	
1	Red and white	Power cord (12V)	
2	Light blue	Right turn lamp	
3	White and grey	Communication A	
4	Black	Negative electrode	
5	Blue	High beam	
6	Violet and gray	Communication B	
7	Yellow	Left turn lamp	
8	/		
9	Black and white	Earth 485	
		  	



How to replace Display (Ref: 006)

Display

1. Screw up three Hexagon flange nuts



2. Connect dashboard connector

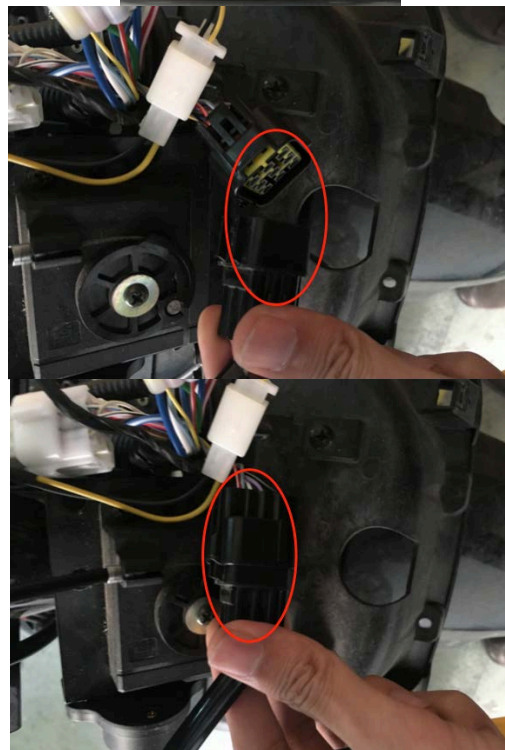





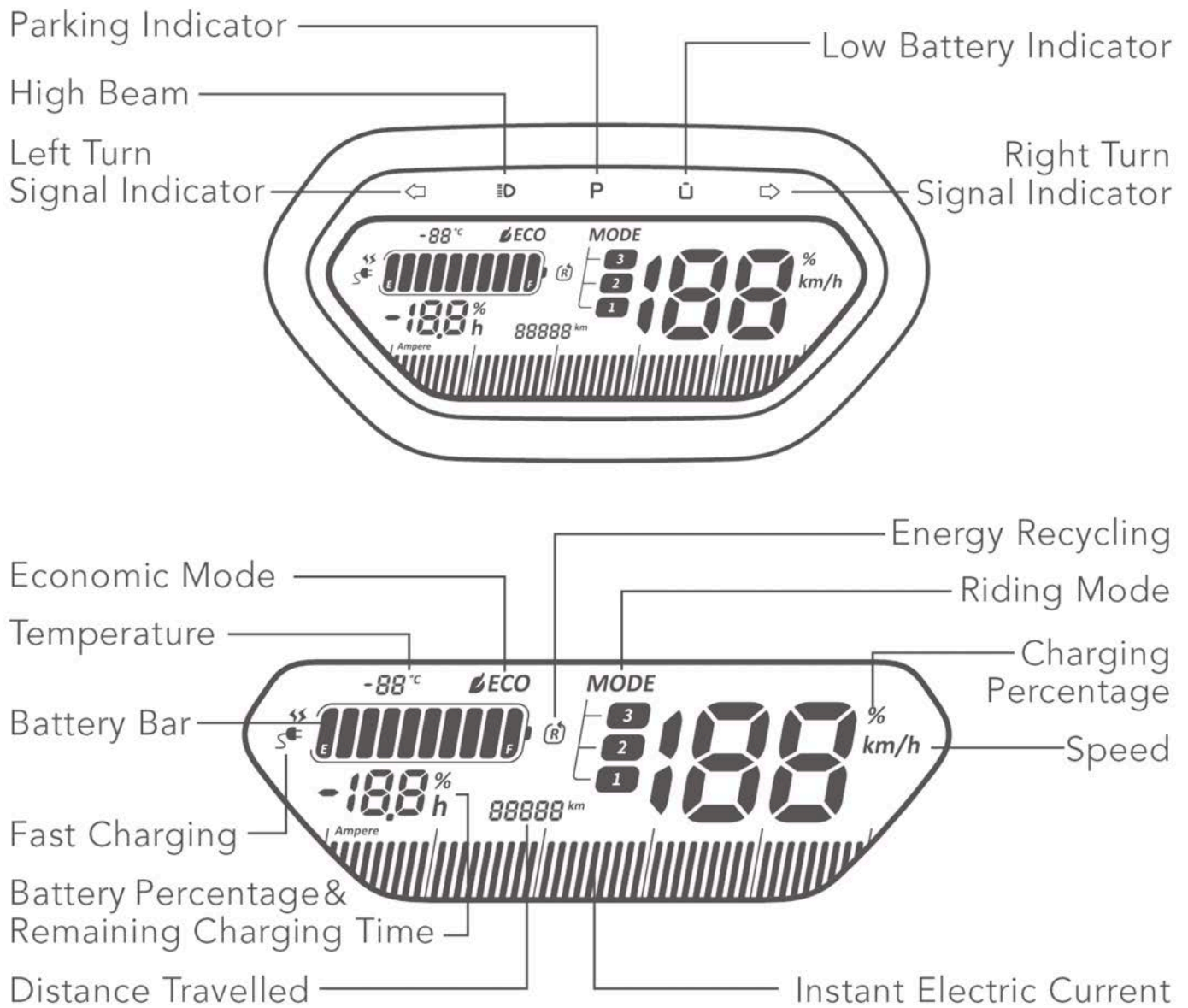













Description of Display





Description of Display

	Left Turn Signal Indicator	The Left Turn Signal Indicator is on.
	Right Turn Signal Indicator	The Right Turn Signal Indicator is on.
	High Beam	The High Beam is on.
	Parking Indicator	In Parking Mode.
	Low Battery Indicator	Battery level less than 20%.
	19°C Temperature	The temperature now is 19°C.
	ECO Economic Mode	Ideal energy consumption status.
	Energy Recycling Status	Energy is being recycled from braking.
	MODE Riding Mode	Mode 2 is selected*.
	26 ^{km/h} Speed	Current speed is 26km/h.
	13% Charging Percentage (Large)	Current battery charging progress is 13%.
	Battery Bar	Current battery level. E: Low battery (less than 10%) F: Full battery (more than 90%)
	89% Battery Percentage (Small)	Battery level inpercentage is 89%.
	- 3.2 _h Remaining Charging Time	The remaining charging hours is 3.2.
	Fast Charging	In fast charging status.
	00802 ^{km} Distance Travelled	Distance Travelled is 802km.
	Instant Electric Current	Indicates instant power output.



Diagnostic Code - 00 on display

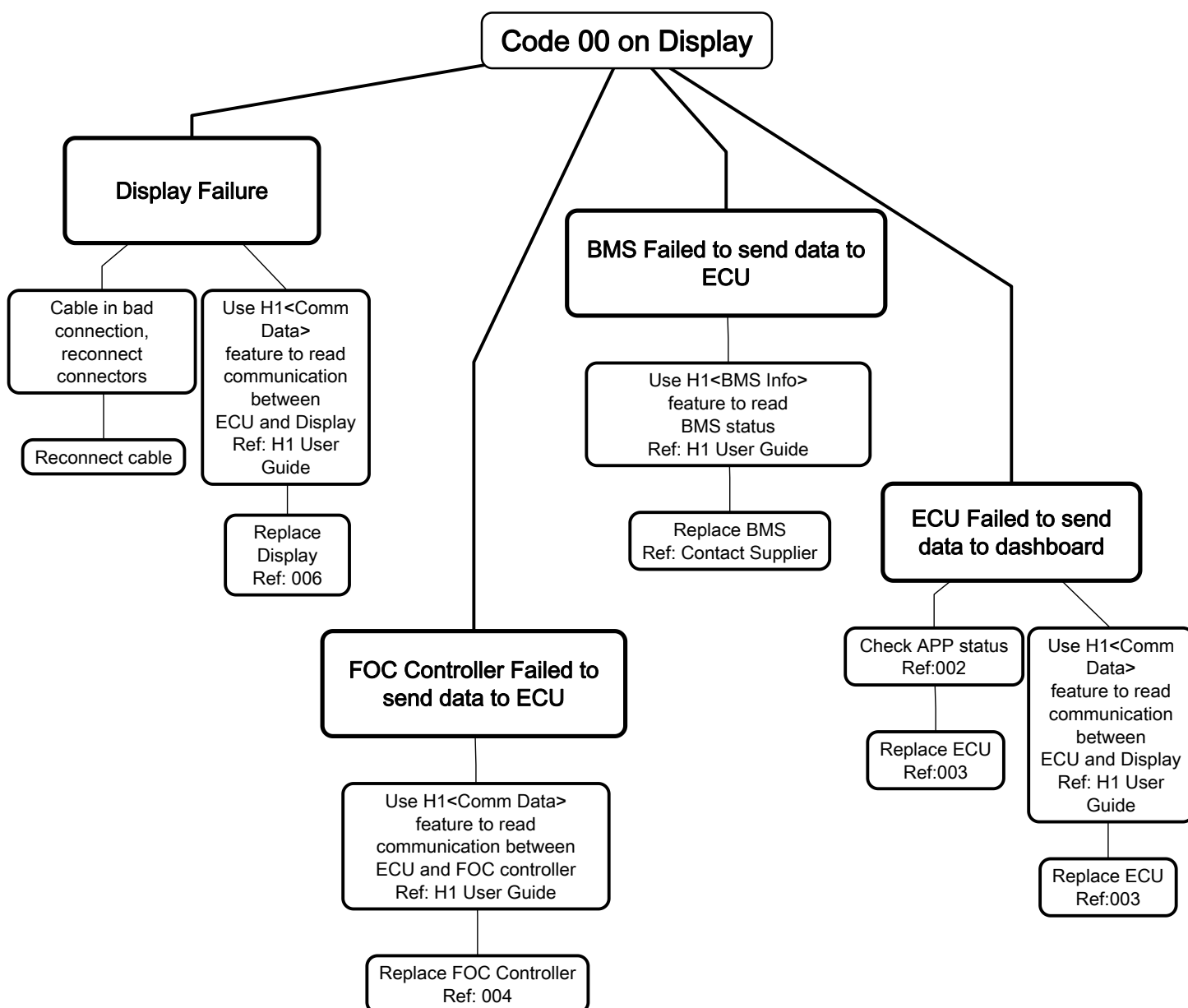
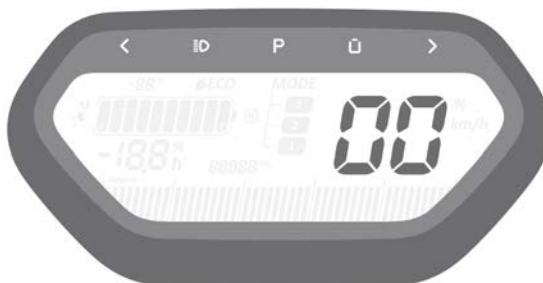



Diagnostic Code - 10/11/12/13 on display

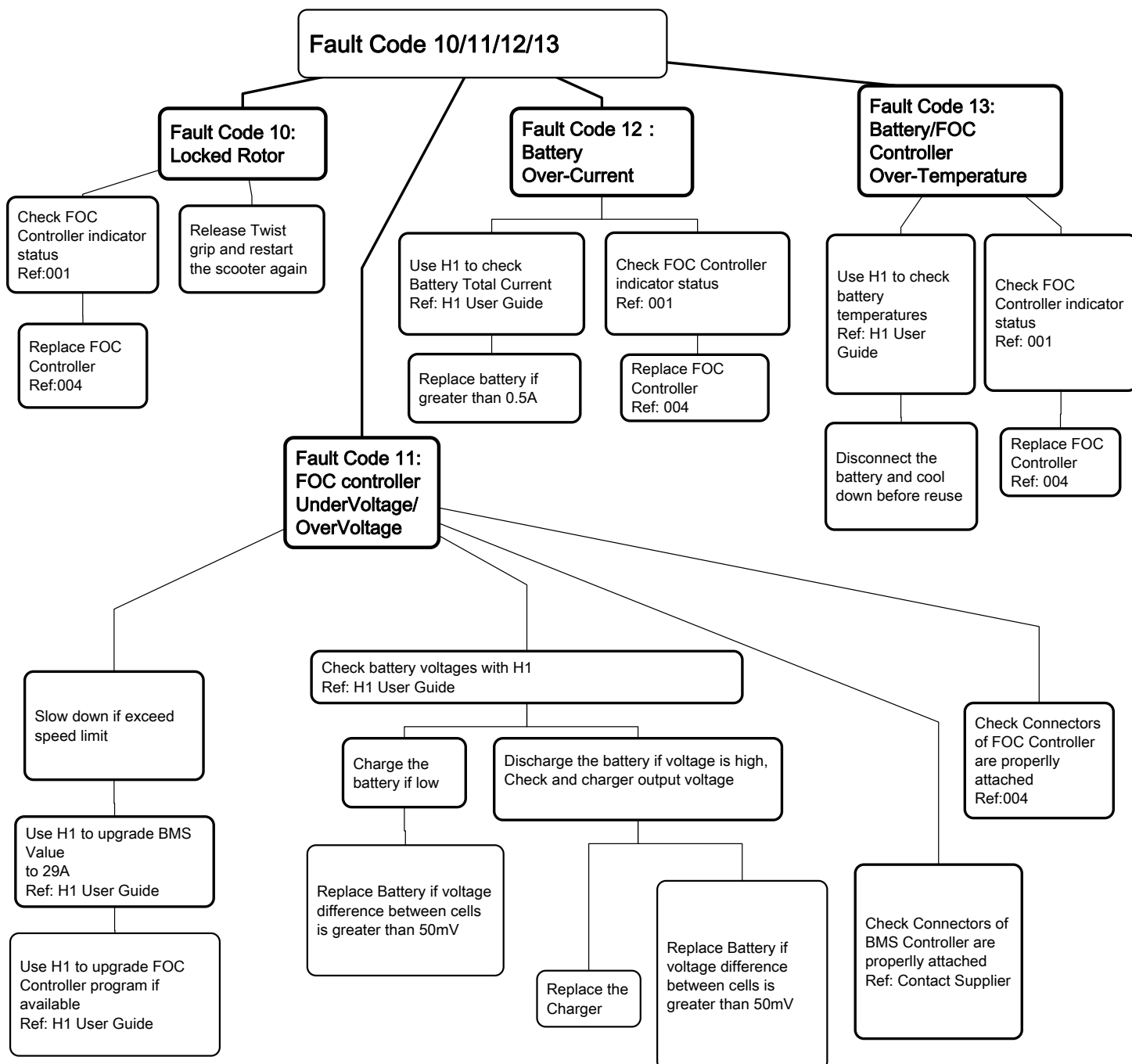



Diagnostic Code - 30 on display

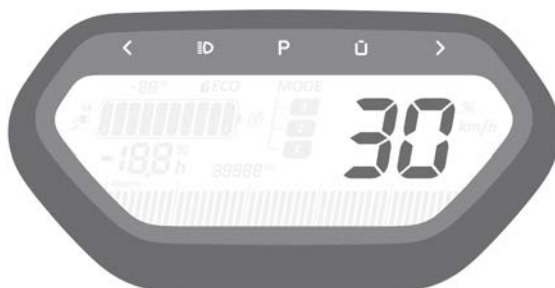

Fault Code 30: Battery Over-Charge Protection

Charger Failure

Try charging the battery with another Charger

Replace Charger

Battery Overcharged

Use H1 to check battery pack Total Voltage
Ref: H1 User Guide

Discharge the battery if overcharged
Note: BMS may stop the charging process to protect battery cells, in cases if the battery can't be charged fully , please charge the battery again.

Use H1 to check single cell voltages
Ref: H1 User Guide

Replace the battery pack if difference in single cell voltages is greater than 50mV



Diagnostic Code - 31 on display

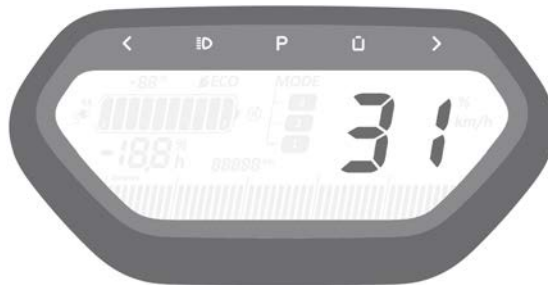

Fault Code 31 Charging Over-Current Protection

Charger Failure

Try charging the battery with another Charger

Replace Charger

Slow down if exceed speed limit

Use H1 to upgrade BMS Value to 29A
Ref: H1 User Guide

Use H1 to upgrade FOC Controller program if available
Ref: H1 User Guide



Diagnostic Code - 32 on display



Fault Code 32 Charging Prohibited at Low Temperature

Battery temperature sensors failure

Use H1 to check Temperature sensors
Ref: H1 User Guide

Replace the BMS if temperature is imbalanced
Ref: Contact Supplier

Battery Temperature LOW (below-20°)

Take the battery pack indoor until back to normal operating temperature



Diagnostic Code - 60/62/63/64/65 on display

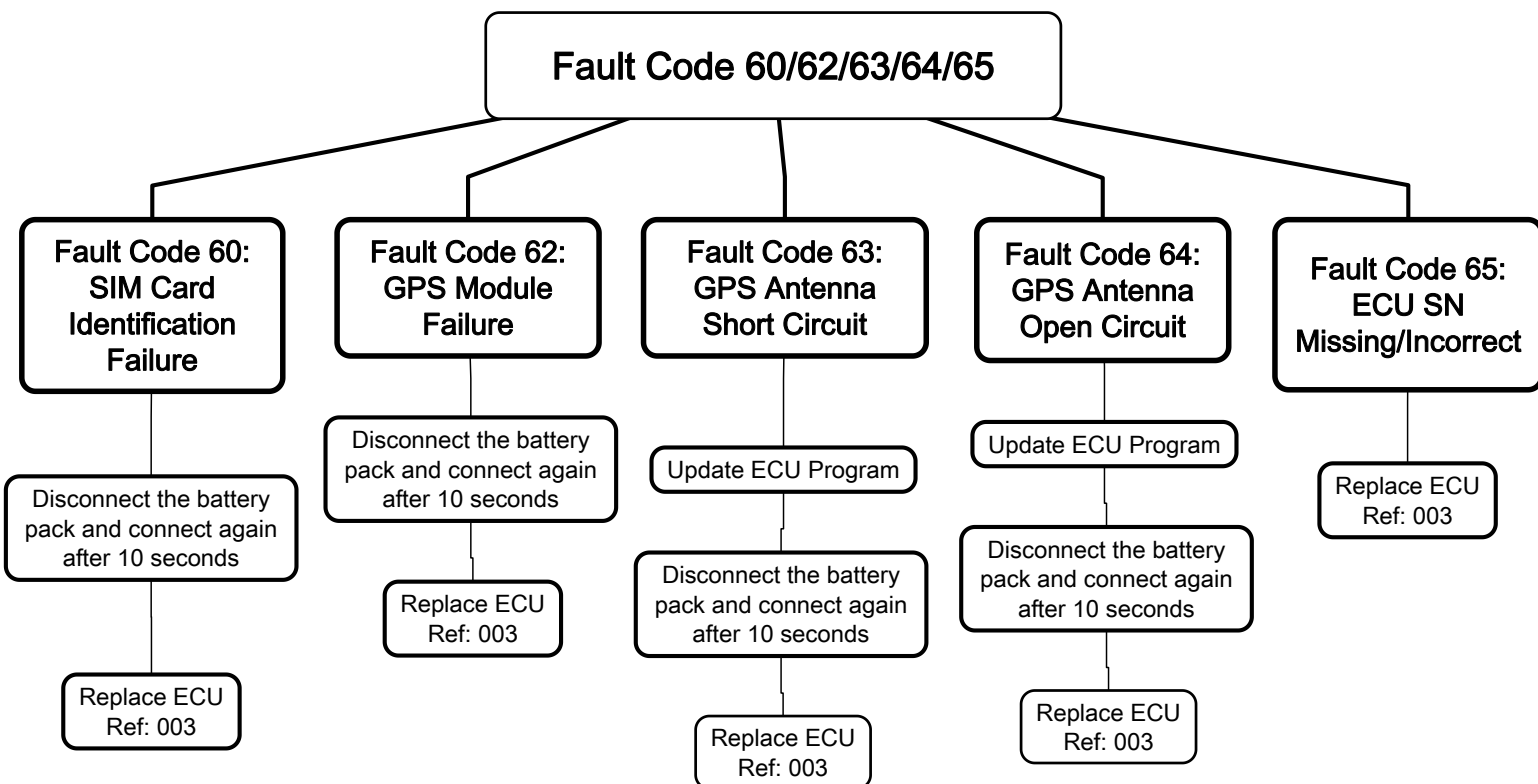



Diagnostic Code - 67 on display

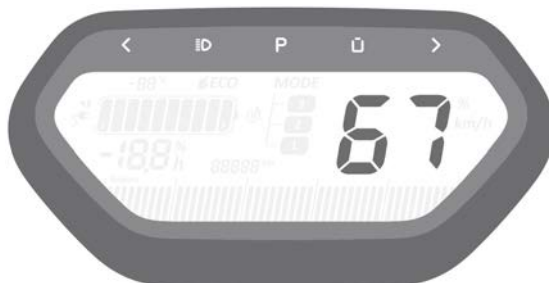

Fault Code 67 Data Service(SIM Card)Unpaid/Inactivated/Low Signal Strength

Renew Top-up App Data Service

Log into App and follow instructions

SIM Card Unpaid/Inactivated

Activate the SIM card
Ref: please follow APP instruction

Update ECU program to Data
Deactivated program to Cancel 67
Warning Code
Ref: H1 User Guide

Use H1 to check Signal Strength Ref: H1 User Guide

Move the scooter to open ground and wait for 10 minutes for better signal reception



Diagnostic Code - 99 on display

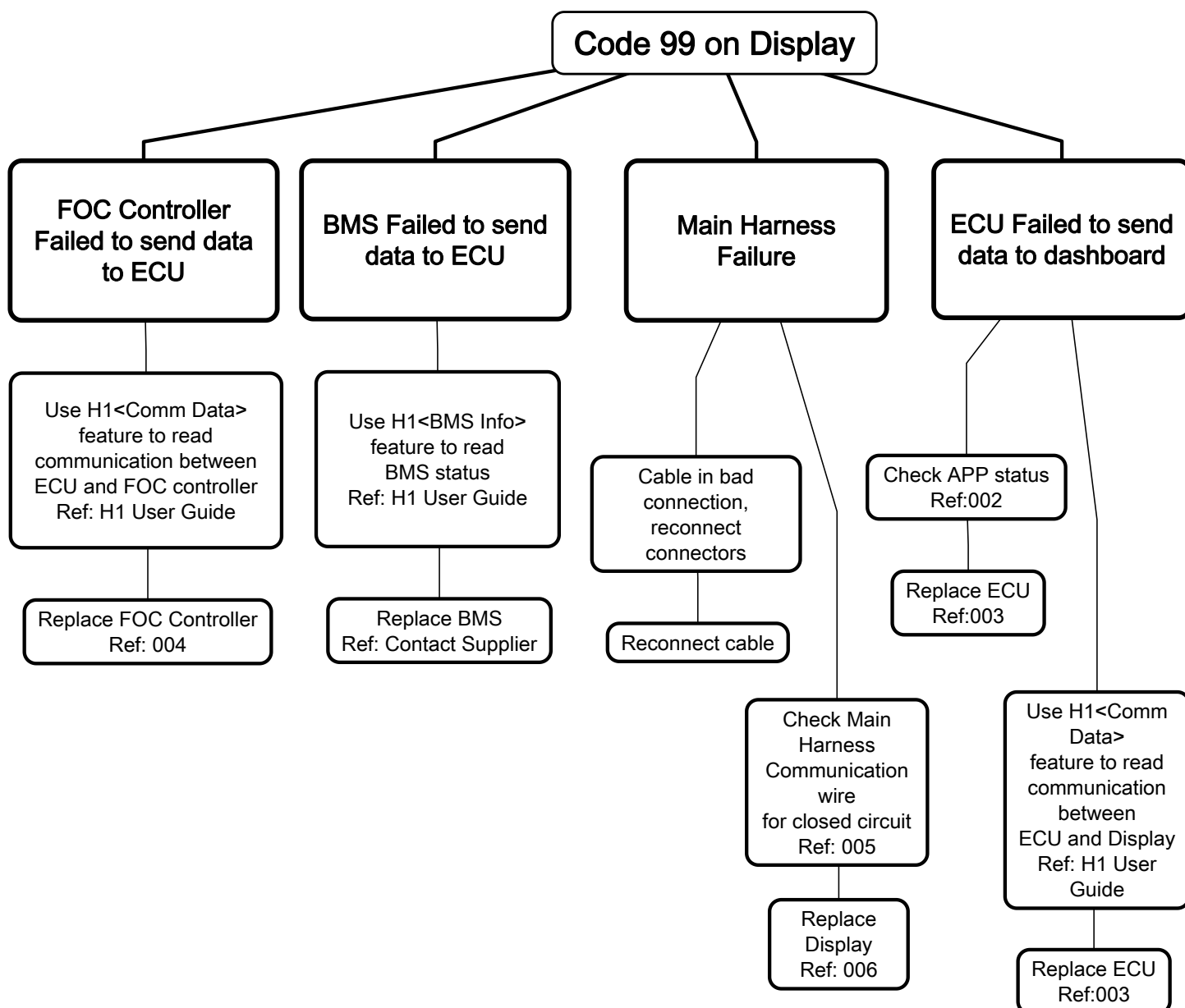
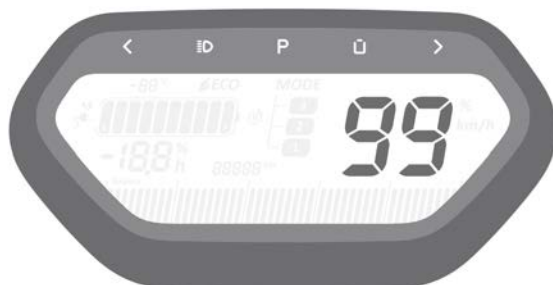



Diagnostic Code - 110 on display

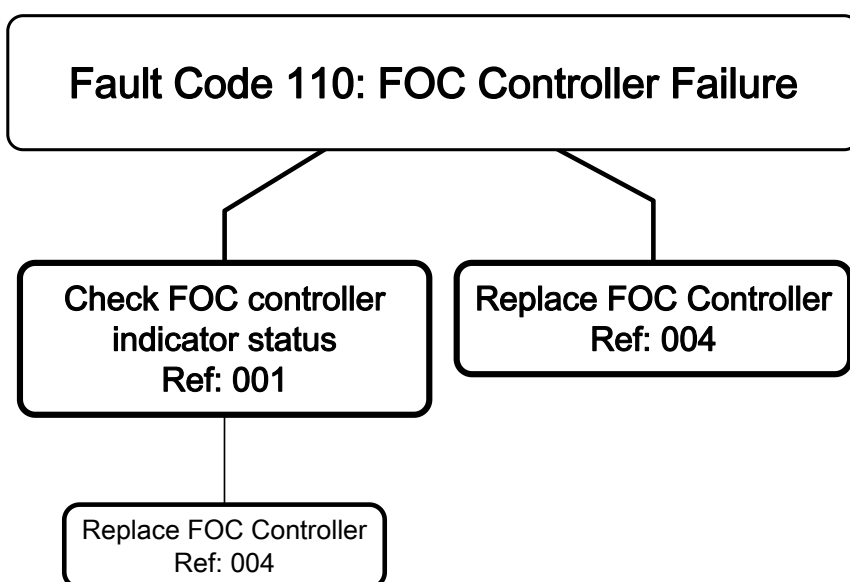
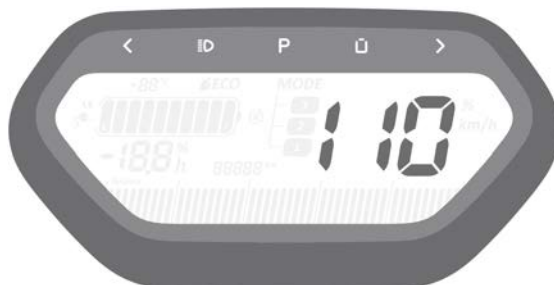



Diagnostic Code - 111 on display

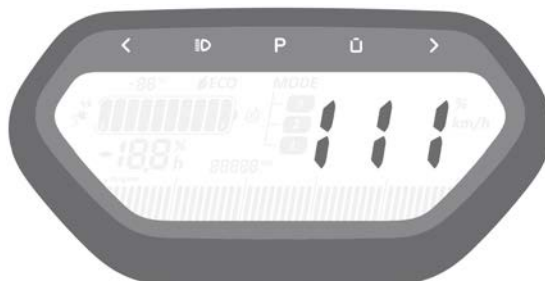

Fault Code 111 FOC : Controller Verification Failure

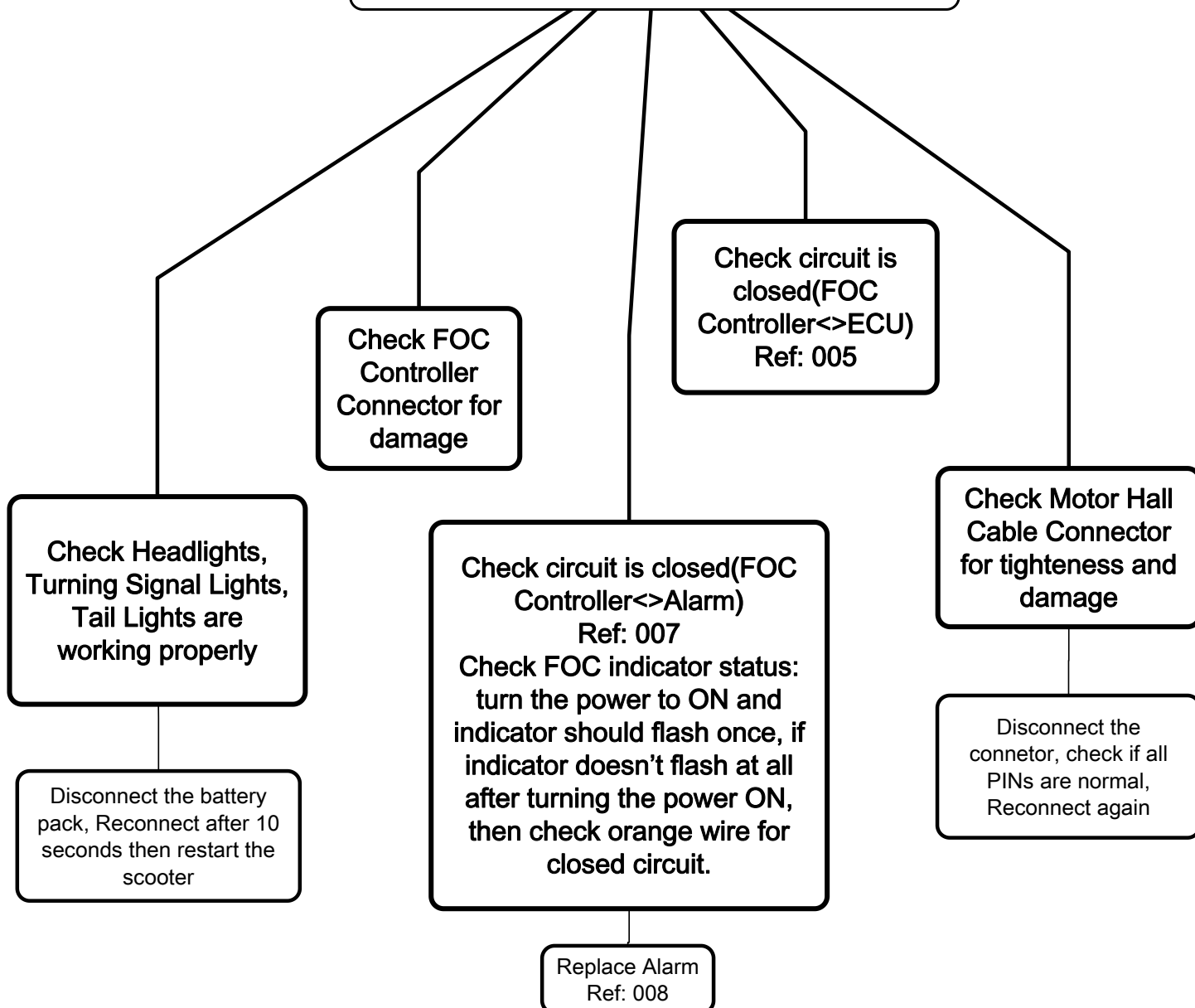



Diagnostic Code - 120 on display



Fault Code 120 Motor Failure

Check FOC
Controller
Indicator status
Ref: 001

Flashing Frequency: 5times
Motor Hall sensor failed

Replace Motor
Ref: 009

Flashing Frequency: 7times
One or more phase cables
missing

Replace Motor
Ref: 009

Motor Hall cable in bad
connection with FOC controller
connector (please check both
connectors between FOC
Controller and Motor)
Please pay attention to vehicles
produced before 12.2016)

Disconnect the Motorl Hall sensor
cable and reconnect again



Diagnostic Code - 130/131/132/133 on display



Fault Code 130/131/132/133

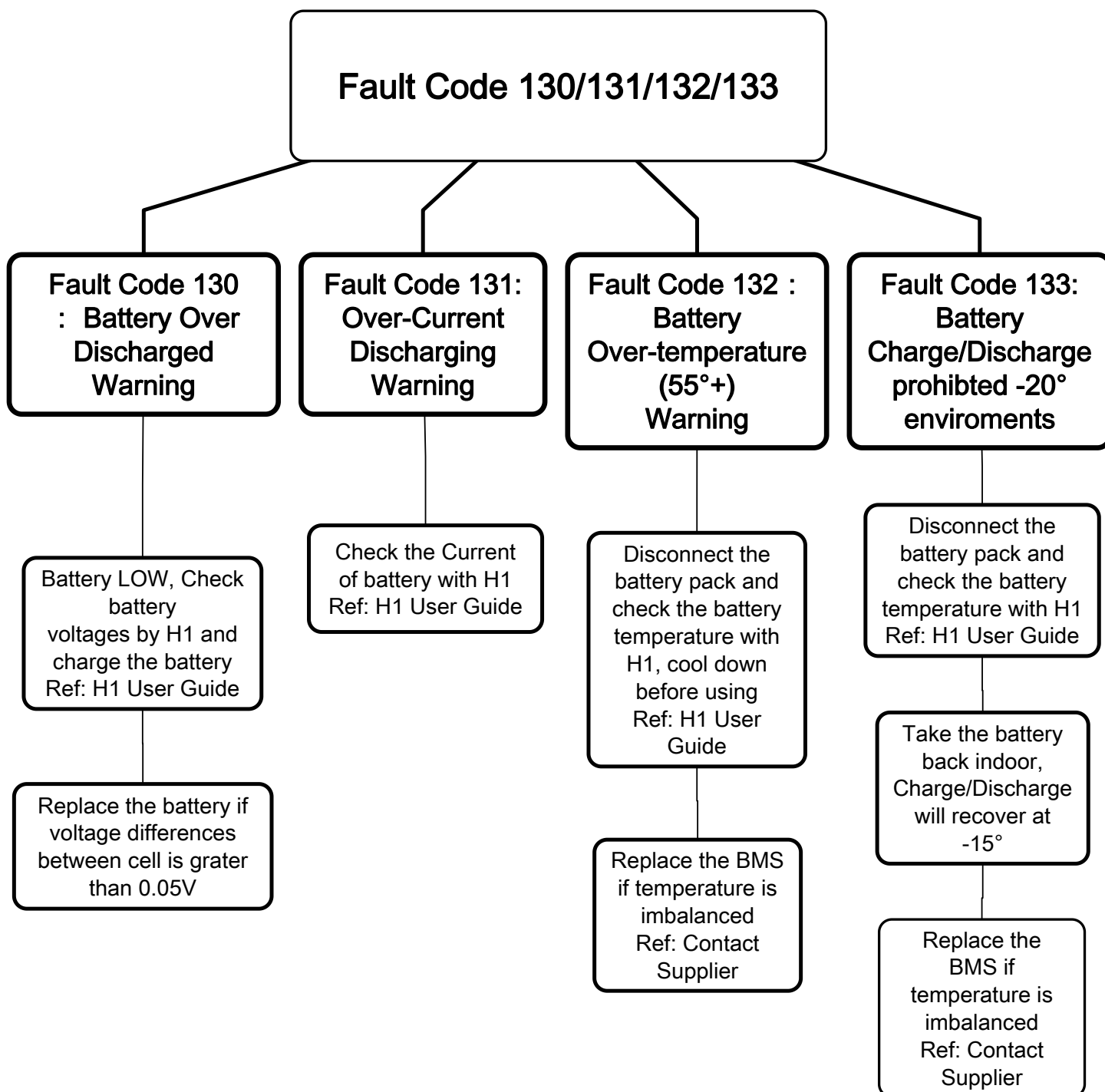



Diagnostic Code - 140 on display



Fault Code 140: Hall Cable Sensor Failure

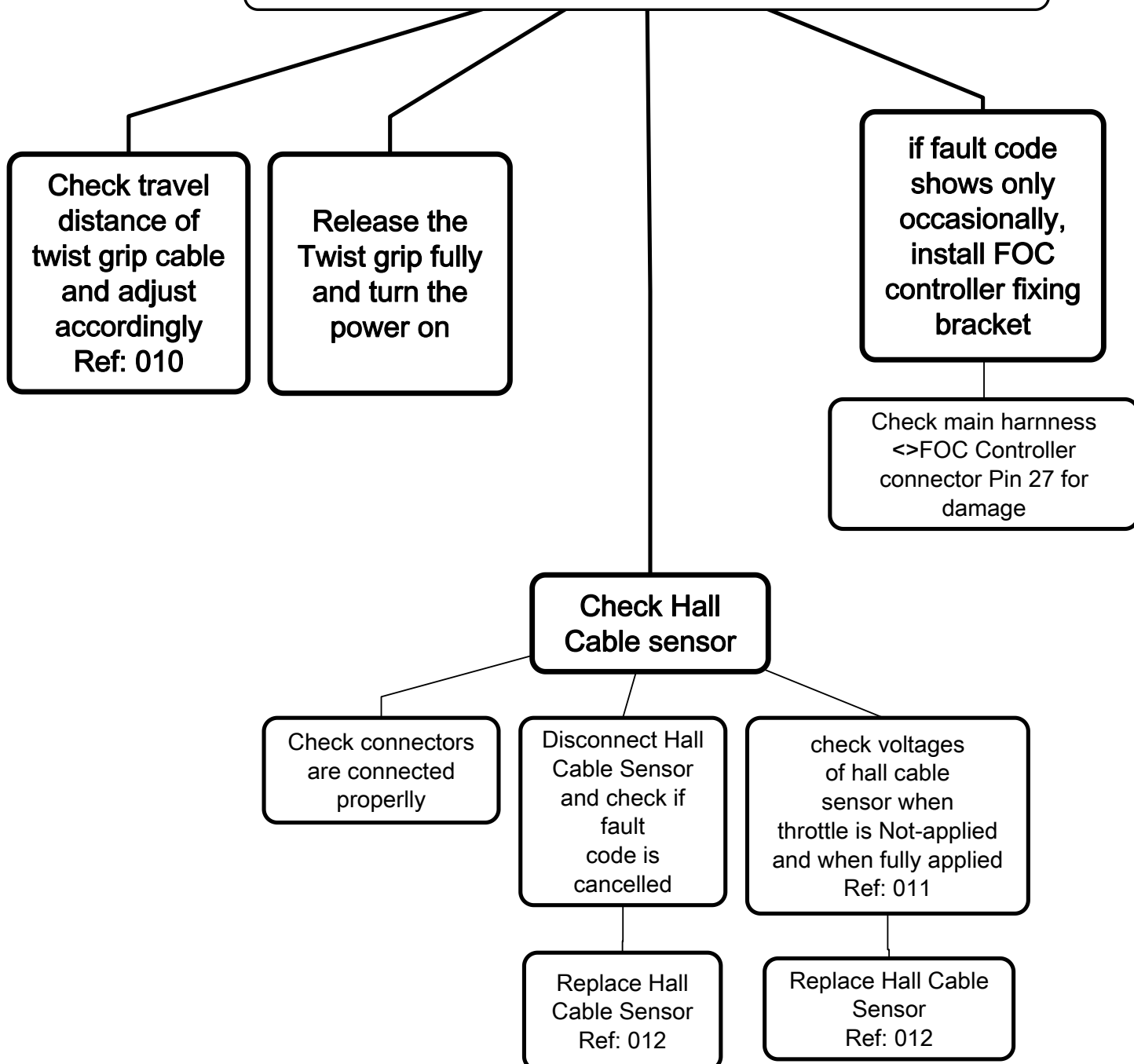



Diagnostic Code - 161 on display



Fault Code 161: Scooter has been locked by remote command

Contact Supplier to unlock



Diagnostic Code - 190 on display

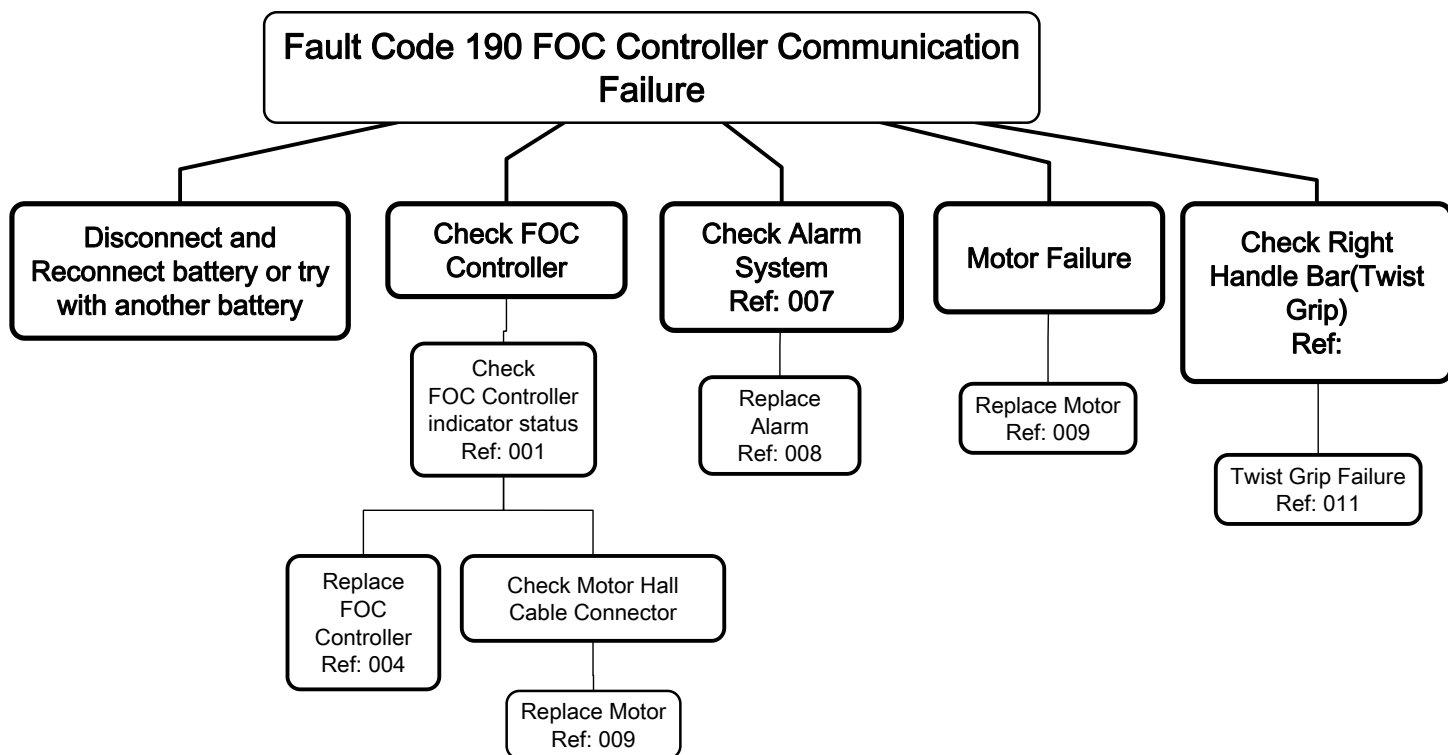



Diagnostic Code - 191 on display

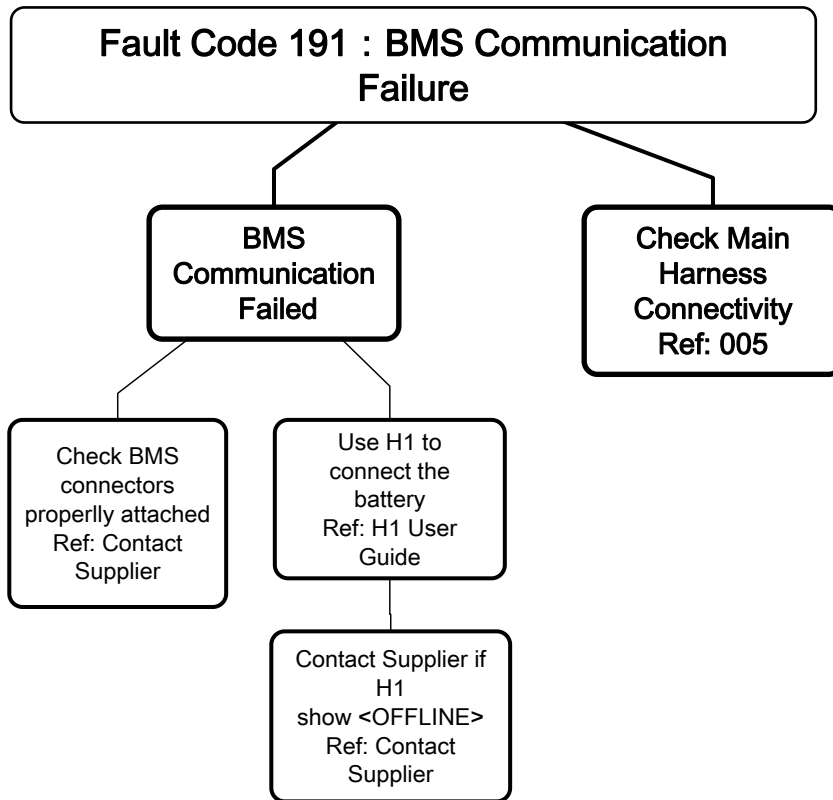



Regular Maintenance Checklist

Overview

The scooter is set on a flat ground before operating. The scooter is inspected, tested, cleaned, adjusted, lubricated or replaced (if necessary) as per items and maintenance cycles specified in the maintenance schedule. The following items require a certain degree of the mechanical knowledge. Some items may require more technical data and tools.

Category	Inspection item	Inspection result
Appearance inspection	Whether there are modifications	
	Appearance of plastic scooter parts	
	Screws and fasteners	
	Front and rear shock absorbers	
	Gap and deformation	
Fixed assembling	Lock and hook assembling	
	Steering inspection	
	Front and rear tires	
	Front wheel and wheel-hub assembly	
	Inspection of the front and rear axles for tightening	
	Single/dual supports	
	Handrail	
	Left and right handles	
Braking system	Brake fluid volume	
	Assembly clearance	
	Abnormal brake noise	
	Response time	
	Braking distance	
	Appearance inspection	



Regular Maintenance Checklist

Electronic Components	Power lock	
	Lighting inspection	
	Instrument inspection	
	scooter insulation	
	Alarm and horn	
	EBS energy recovery	
	Controller inspection	
Wheel-hub motor	Wire connection and appearance	
	Inspection for abnormal noise	
	Startup inspection	
	Tolerance and deformation	
Software	ECU software version	
	FOC software version	
	Display software version	
	BMS 29Ah setting (60V29Ah pack only)	



Regular Maintenance Checklist

Inspection of the Accelerator Handle

- Check the accelerator handle for smooth operating.
- Check the accelerator handle for smooth opening and automatic resetting at all steering positions of the steering handle.
- Check the accelerator handle cable if the accelerator handle can not be reset as usual.

Inspection of Brake Pads wearing

- Check the brake pads for wearing.
- The brake pad of a brake that has been worn to the extent indicated by the wearing limit indication groove should be replaced.
- The brake pads should be replaced in pair to ensure uniform pressure on the brake disc.

Inspection of Brake Handle

- Check connection of the brake handle for looseness.
- Check the brake handle for excessive free travel or other damages.
- Perform replacement or reparation if necessary.

Inspection of Brake fluid

- The leaking brake can damage coatings, plastics or rubber parts. They should be well covered with cloths or paper sheets during the system maintenance.
- Do not use different types of the brake fluid because they are not compatible with each other.
- Do not let foreign objects enter into the braking system in filling the fluid reservoir with the brake fluid.
- Check the brake pads for wearing if the brake fluid level is around the lower-limit horizontal scale
- A low level of the brake fluid may result from wearing of the brake pads that causes push-out of the brake caliper piston.
- Check the entire system for leakage if a low level of the brake fluid occurs without wearing of the brake pads.
- Lift up the scooter with the central stand. Turn the steering handle reversely to make the fluid reservoir horizontal, and check the brake fluid level in the front brake fluid reservoir through the glass observation hole.

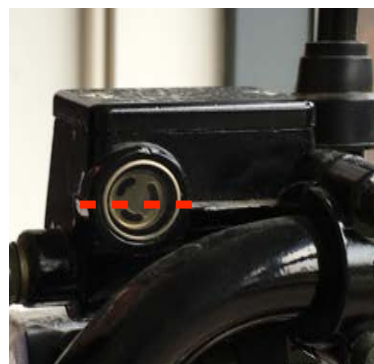



Regular Maintenance Checklist

Inspection of Brake Lamp Switch and Front/Rear Brake

- The brake switch on the brake handle can not be adjusted
- Make sure that the brake lamp turns on in actual application of the brake. Replace the front/rear brake switch or other faulty components in the braking system, if turn-on of the front brake switch is not synchronous with brake application



Inspection of Lamp System and Switches

- Turn on the ignition switch to check left and right combination switches
- Make sure that the corresponding light turns on to actual switch application
- Make sure that the light brightness and flashing are normal
- Make sure the horn sounding is normal
- Make sure the startup button operates normally
- The speed regulation switch operates normally, and the switching between high and low beams is normal

Inspection of Side Stand

- Lift up the scooter with the Central Stands.
- Check the Side Stand spring for damages or tension loss.
- Check the Side Stand assembly for free movement.
- Lubricate the Side Stand pivot where necessary.

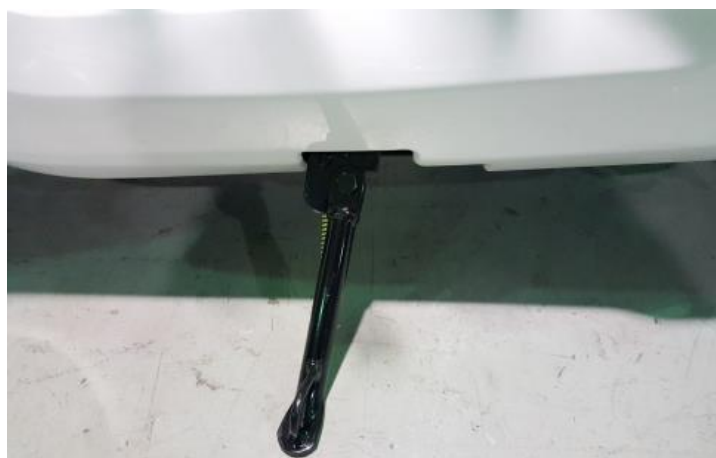



Regular Maintenance Checklist

Inspection of Suspension system

Front suspension

- Operate the front brake and check the front suspension system by pressing down the handle bar for several times to check motion of the fork.
- Check the entire assembly for leakage, damages or loosened fasteners.
- Replace damaged components that can not be repaired.
- Tighten all the nuts and bolts.

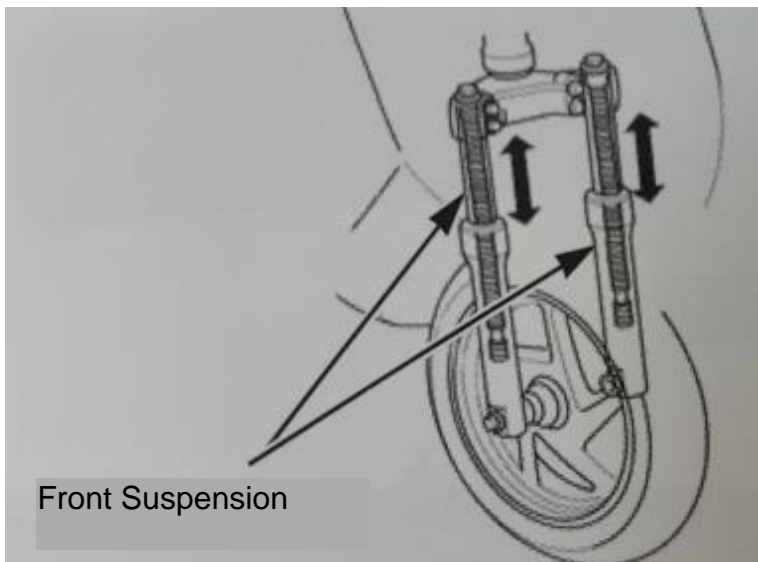

Rear suspension

- Press the rear shock absorber for several times to check its motion.
- Check the entire shock absorber assembly for leakage, damages or loosened fasteners.
- Replace damaged components that can not be repaired.
- Tighten all the nuts and bolts.
- Lift up the scooter with Central Stands.
- Hold both sides of the rear shock absorber and try to move it leftward and rightward to check free travel distance.

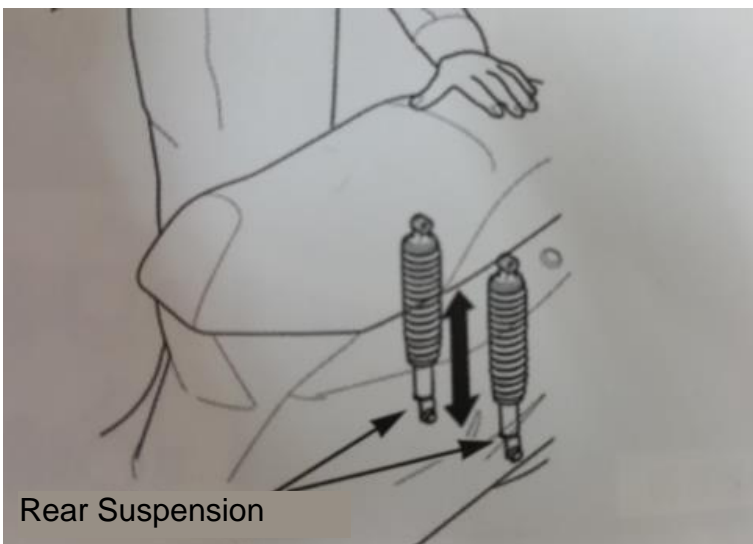



Regular Maintenance Checklist

Nuts, Bolts and Fasteners

- Make sure that all nuts and bolts on the chassis have been tightened as per correct torque values.
- Make sure that all the split pins, safety clips, hose clamps and wire cables have been placed properly and secured tightly.

Inspection and maintenance of fasteners

Tightened section and fastener name	Tightening Torque (Nm)
Installation screws on the front hydraulic brake plate	8Nm
Tightening bolts on the front shock absorber	28Nm
Tightening bolts on the fixed handle seat cover	8Nm
Tightening bolts on the welded steering handle assembly	52Nm
Front axle	60Nm
Installation screws on the rear hydraulic brake plate	8Nm
Self-locking nuts on the motor	75Nm
Top bolts on the rear shock absorber	44Nm
Bottom bolts on the rear shock absorber	28Nm
Tightening screws on the hex flange of rear handrail	28Nm
Tightening nuts on the fixed shaft of rear bottom fork	60Nm



Regular Maintenance Checklist

Inspection of Wheels and Tires

- Support the scooter with the Central Stands.
- Lift up the Front/Rear Wheel to check range of the free travel.
- Hold the Front/Rear Wheel and try to move it leftward and rightward to check the front wheel bearing for wearing.
- Replace the Front/Rear Wheel bearing if it becomes loosened.
- Turn the wheel to make sure that it can be rotated smoothly without an abnormal noise.
- The Front/Rear Wheel bearing should be inspected as long as there are suspicious abnormal conditions.

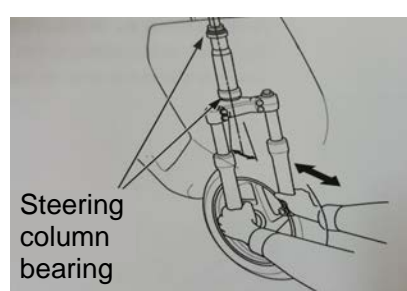
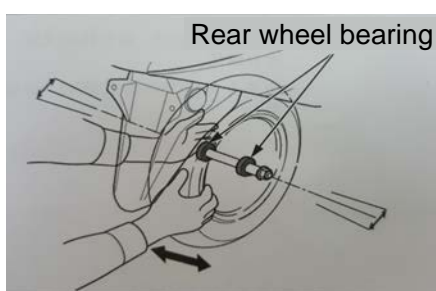
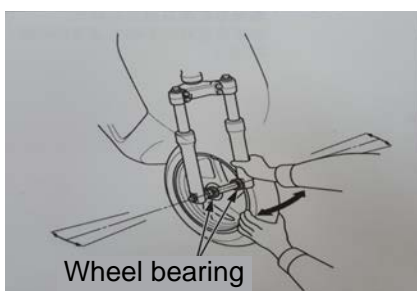

- Check the tire pressure with the tire pressure gauge when the tire has been cooled down.
- Recommended tire pressure:

Front tire	20-25psi
Rear tire	26-32psi

- Check the tire for cuts, embedded nails or other damages.
- Check flatness of the front and rear wheels.
- Check tread depth.

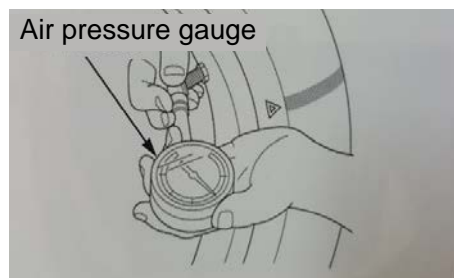



Regular Maintenance Checklist

Steering column bearing

- Support the scooter with Central Stands, and lift up the Front Wheel to make it off the ground.
- Make sure that scooter handles can be turned freely to left and right sides.
- Check the steering column bearing, if scooter handles are not moving smoothly or are stuck.

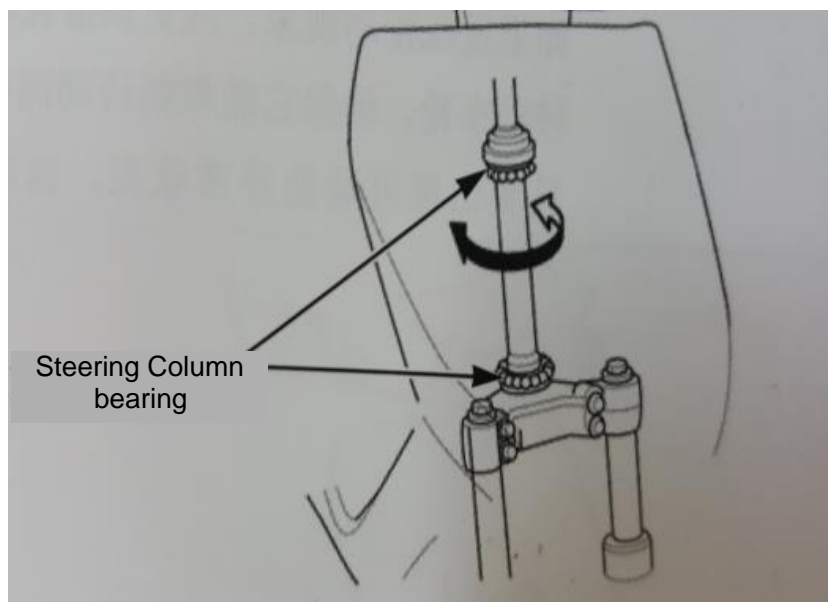

- Fix the scooter and move the fork back and forth to check the steering column bearing for wearing.
- Check the steering column bearing if the steering column is displaced vertically.

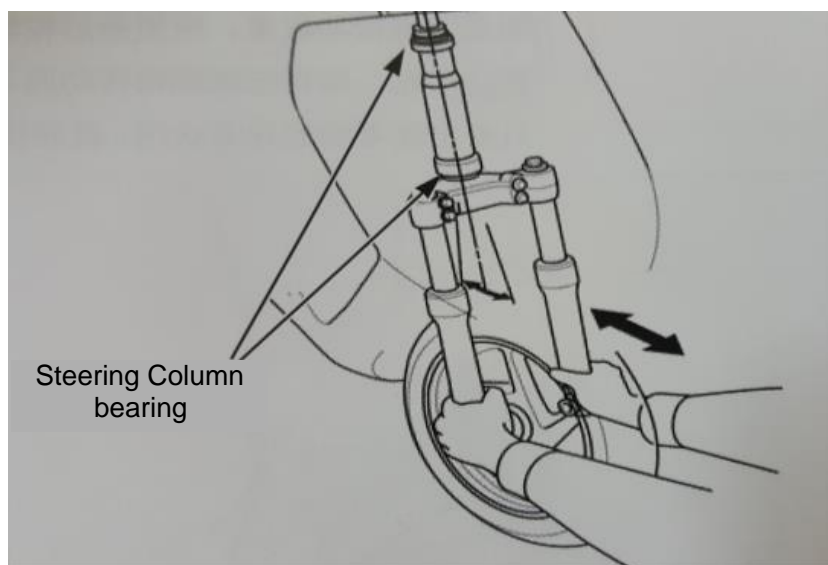



niu.com