



# **Alrendo Motorcycles**

User Manual  
TS Bravo

# Contents



3. Introduction
4. Identification Numbers VIN
5. Specifications
6. Specifications
7. Specifications
8. Steering Angle
9. Footrests
10. Features
11. Controls and Instruments - Left
12. Controls and Instruments - Right
13. Ride Modes
14. TFT Display
15. Temperature Gauges
16. General Safety Precautions
17. Ignition Switch
18. How to Get Started
19. Throttle Control
20. Charging
21. Charging and Storing
22. Battery Pack
23. Cleaning Your Motorcycle
24. Cleaning Your Motorcycle
25. Extending Your Range
26. ABS System
27. Your Responsibilities
28. Maintenance
29. Maintenance
30. Maintenance
31. Torque Settings
32. Torque Settings
33. Brakes and Suspension
34. Suspension – Front Adjustment
35. Suspension – Rear Adjustment
36. Brake Fluid
37. Brake Fluid
38. Brake Discs and Pads
39. Brake Discs and Pads
40. Tyres
41. Drive Belt
42. Drive Belt
43. Electric Motorcycle Precautions
44. Error Codes
45. Weather Conditions
46. Collision Warnings
47. Maintenance Records
48. Maintenance Records
49. Maintenance Records
50. Warranty
51. Warranty
52. Warranty
53. Warranty
54. Warranty - Battery
55. Dimensions

# Introduction



**Congratulations and thank you for purchasing your new Alrendo TS Bravo electric motorcycle.**

We welcome you to the community of Alrendo Motorcycles riders. This manual is designed to provide you with a better understanding of the operation, inspection, and basic maintenance requirements of your new motorcycle.

Vehicles produced by Alrendo may change throughout their production lifespan. Therefore, this manual contains the most current product information available at the time of printing. Because of this, your motorcycle may differ from the information supplied in this owner's manual. No legal claims can be made on the basis of data in this manual.

If you have any questions concerning the operation or maintenance of your motorcycle, please contact Alrendo at

[info@alrendo.com](mailto:info@alrendo.com).

For more information visit our website:  
<http://www.Alrendo.com>

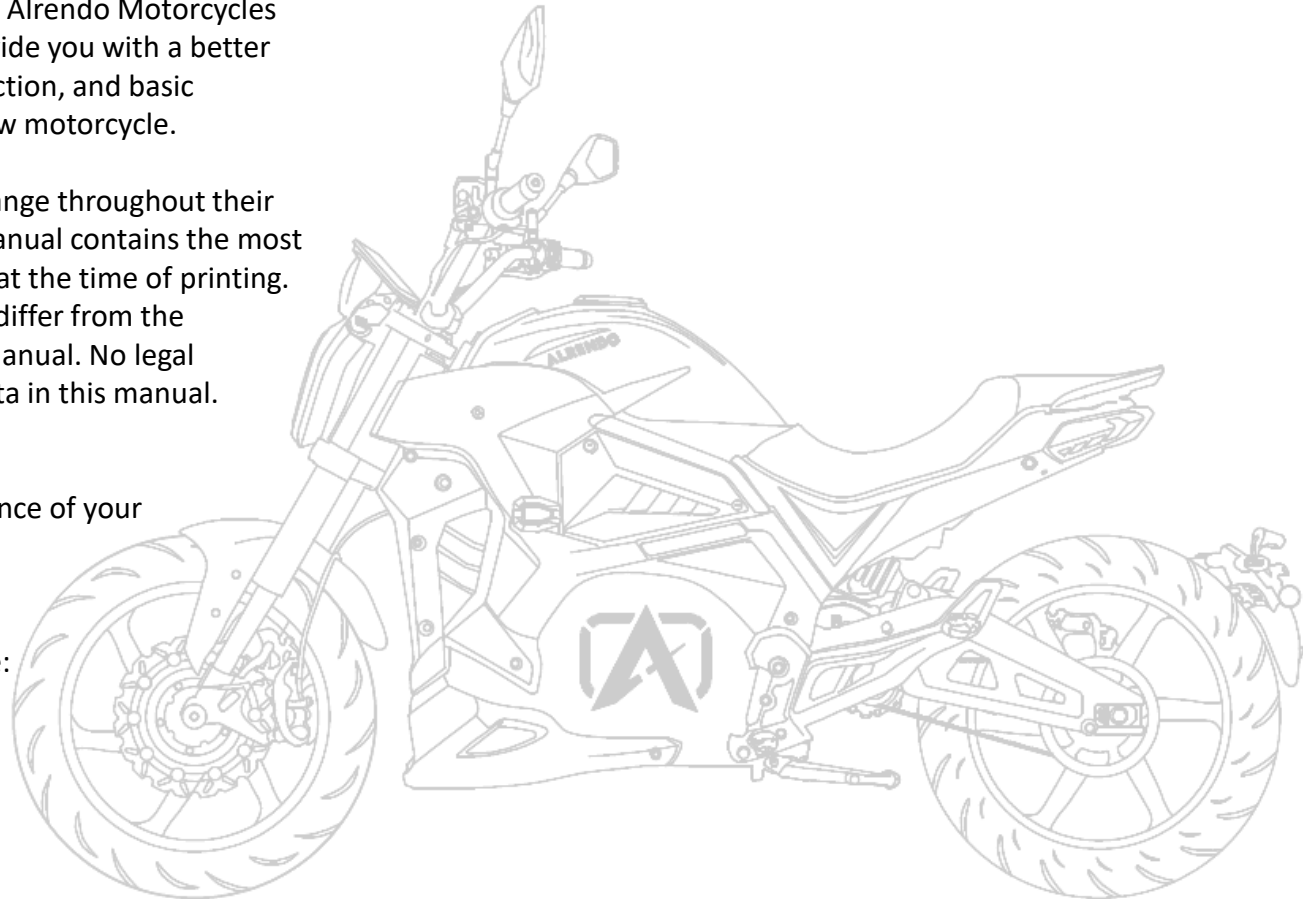

# Identification Numbers - VIN

## Vehicle Identification Number

The VIN is a 17-digit number stamped on right side the head tube of the frame. Do not alter or remove this number as it is the legal identifier for your motorcycle.

## Statutory Plate

The Statutory plate is included factory's information and dimension of the motorcycle.

## Motor Serial Number

The motor serial number is stamped on the motor housing.

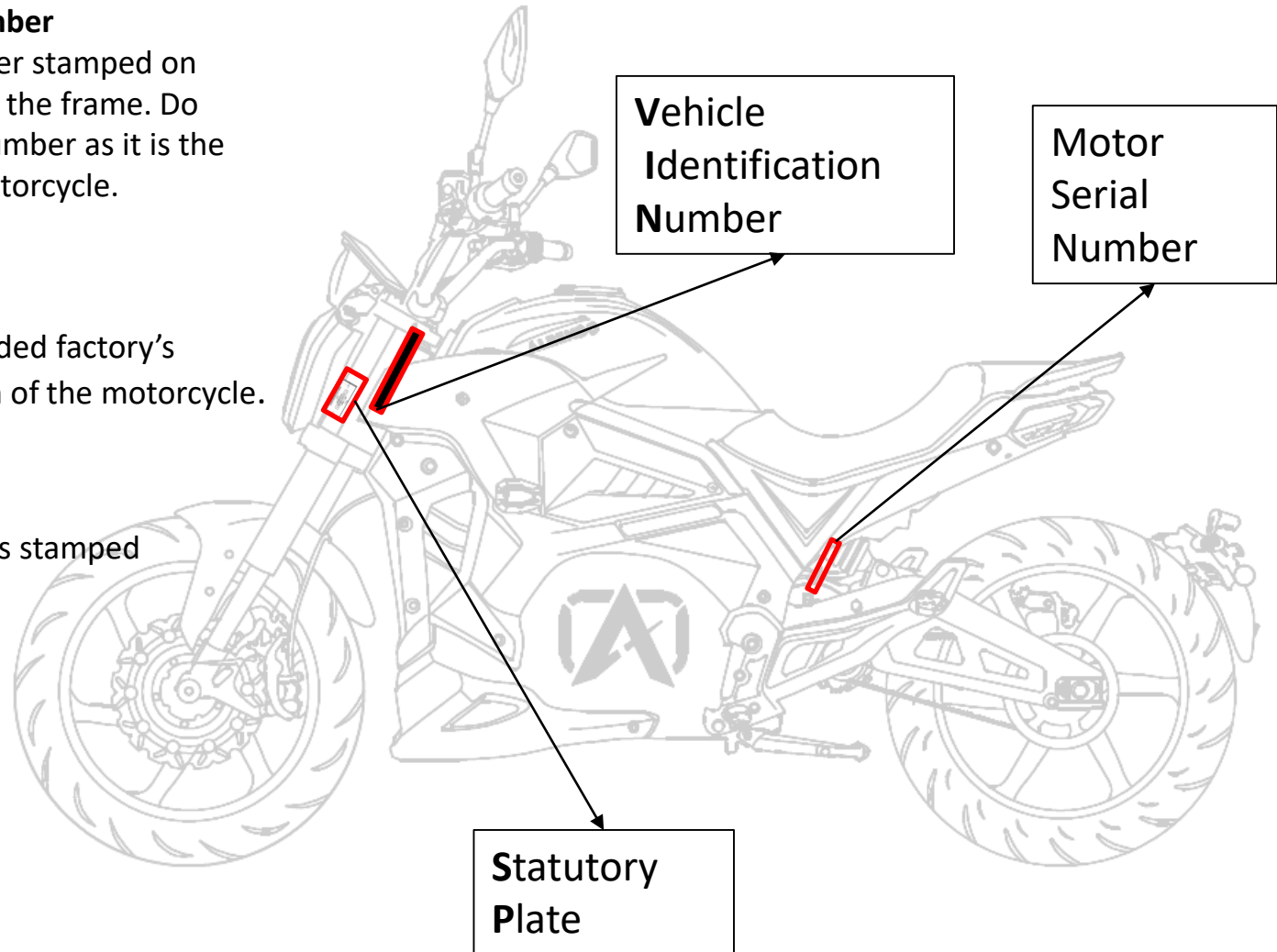

# Specifications

## Tyres & Brakes

ABS brake system

Front Brakes: Dual 300mm Discs with 4 Piston Caliper

Rear Brakes: 240mm Disc with Dual Piston Caliper

Front Tyre: 120/70/17

Rear Tyre: 180/55/17

Tyre Brand: Timsun TS-689

## Suspension

Adjustable Front Damping

Inverted Forks

Adjustable Rear Spring

Nitrogen Filled Rear Gas Strut

41mm Diameter Front Suspension

120mm Front Suspension Travel

73.5mm Diameter Rear Spring

## Range

City: 438km (273 miles) @50km/h

Combined (NEDC): 278km (173 miles) @80km/h

Highway: 160km (100 miles) @120km/h

## Motor

Max Torque: 117.6Nm (86.7 ft-lb)

Max Power: 20kw

Nominal Power: 11kw

Max RPM: 8500



# Specifications

## Battery

Nominal capacity: 15.0kWh  
Maximum Capacity: 17.4kWh  
Nominal Voltage: 132v  
Max Voltage: 150v  
Weight: 84kgs

## Charger Type

3.8kw On-Board Charger  
Maximum Charging Speed to 100%: 4 hours  
16 amp Schuko Socket: 4 hours  
13 amp UK Socket: 5 hours

## Drivetrain

Pulley and Belt: 88T 25mm Poly Chain Carbon Belt  
Final Drive Ratio: 2.78

## European Vehicle Class

L3e-A1  
11kw (125cc License Equivalent)

## Warranty

Standard Limited Warranty  
2 years / 20,000km  
Battery Pack Warranty  
3 years / 30,000km

## Performance

Top speed: 135km/h (83mph)  
0-100km/h Acceleration: 8 seconds  
Type: Liquid Cooled Permanent Magnet AC Motor



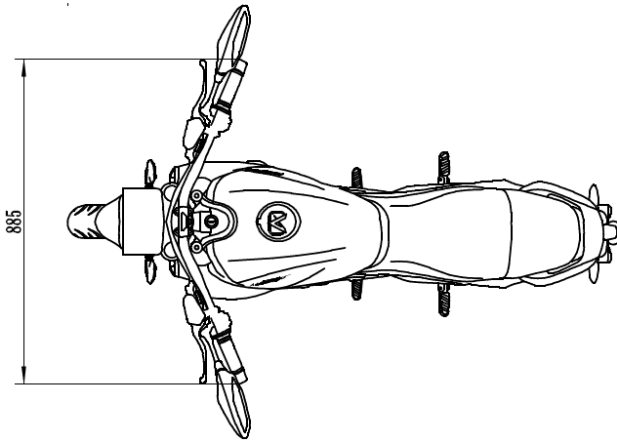
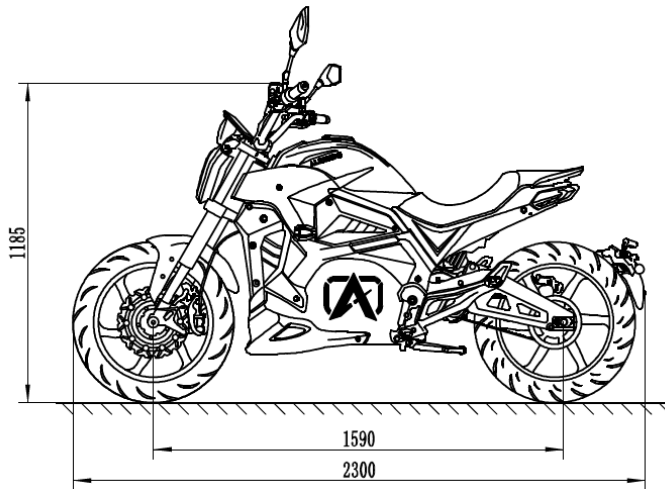

## Dimensions

- Seat Height: 760mm (30 Inches)
- Height: 1185mm (47 Inches)
- Width: 885mm (34 Inches)
- Length: 2300mm (87.4 Inches)
- Ground Clearance: 150mm (5.9 Inches)
- Carrying Capacity: 260KG (573lbs)
- Motorcycle Weight: 245KG (540lbs)
- Boxed Weight: 280kg (617lbs)



# Steering Angle

Maximum steering angle

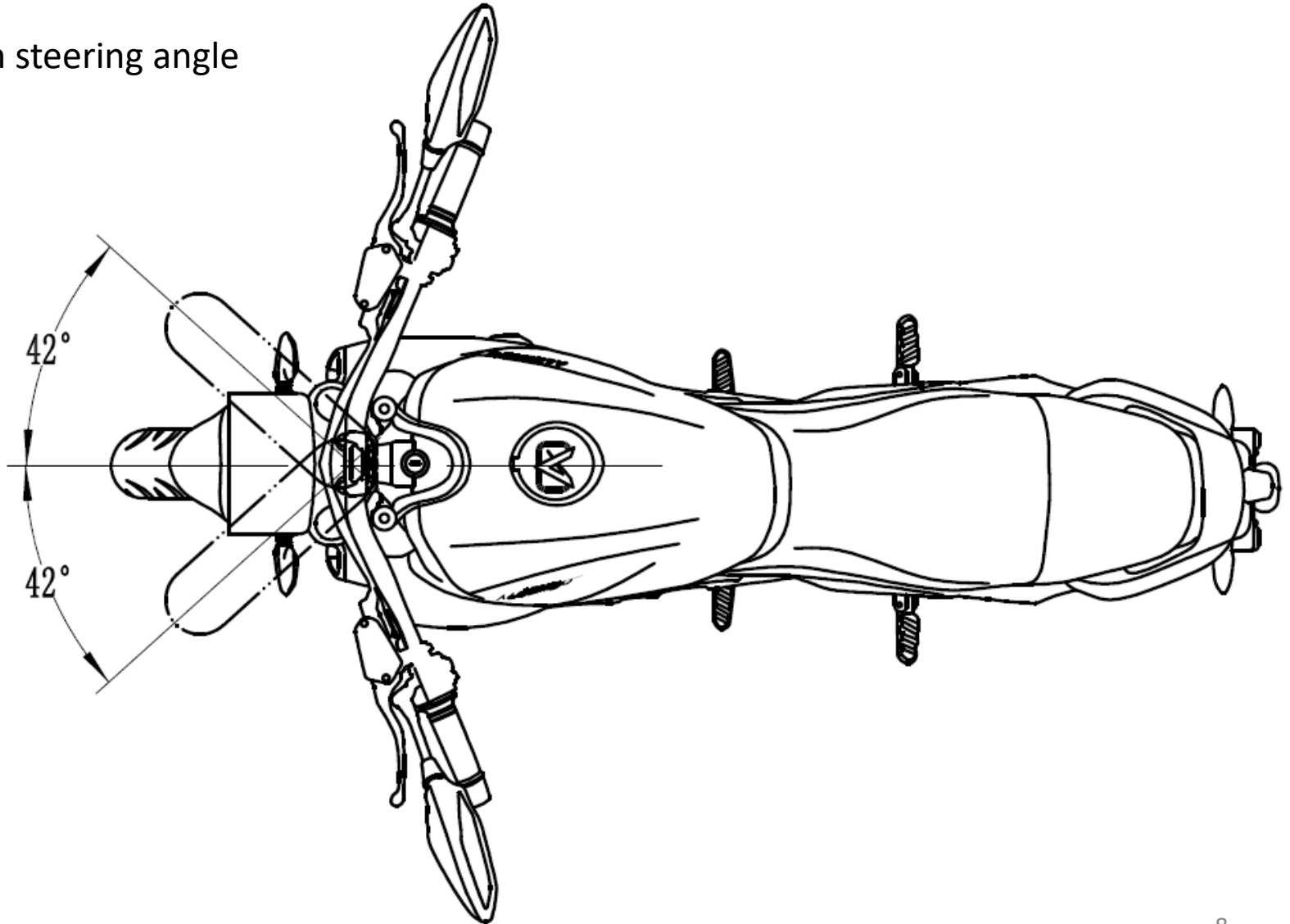

The driver's foot pegs are spring-loaded so should always be in the lowered position.

Passenger foot pegs are usually folded in upright/vertical position. They should only be lowered when carrying a pillion passenger.

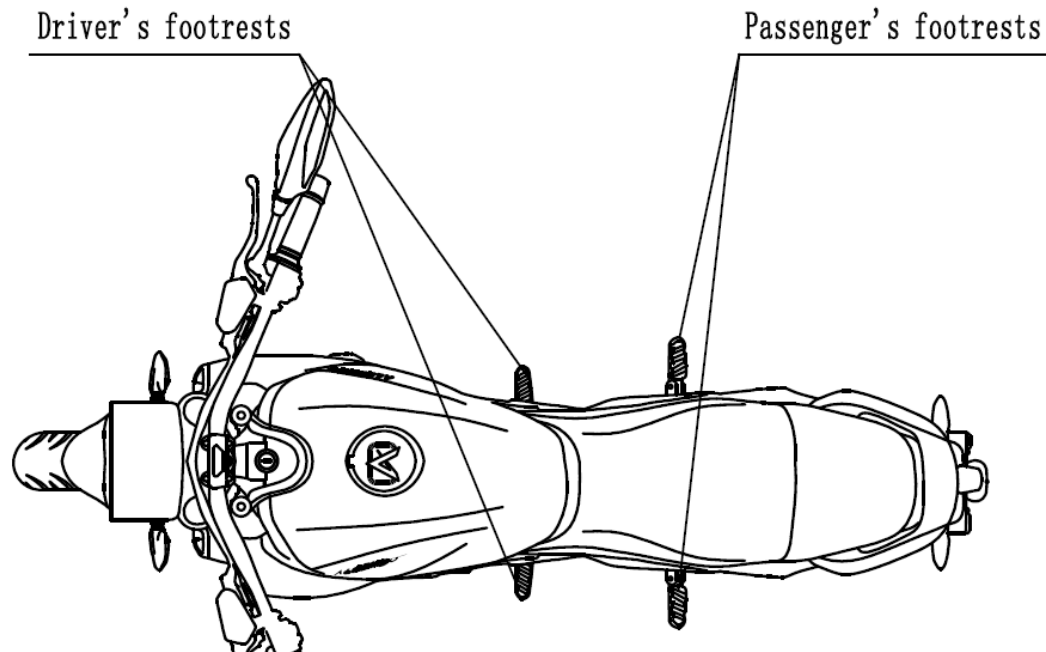

# Features

- A. Handlebars
- B. TFT Display
- C. Head light
- D. ABS sensor
- E. Charging Port
- F. Battery
- G. Kickstand
- H. Rider Seat
- I. Foot peg sets
- J. Rear Suspension
- K. Drive Belt
- L. Rear Belt Pulley
- M. Front Belt Puley
- N. Plate light

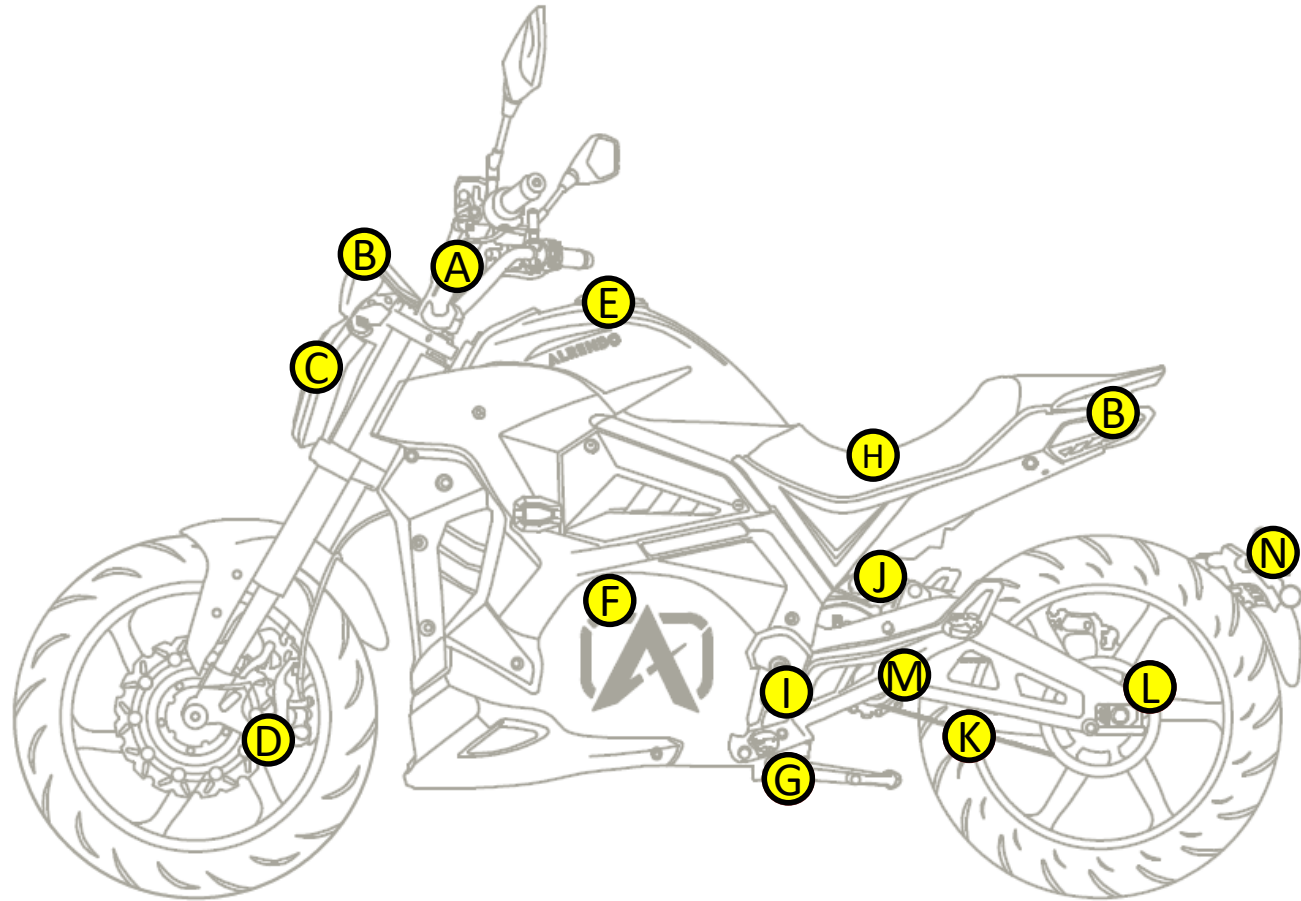

## Left handlebar Switchbox

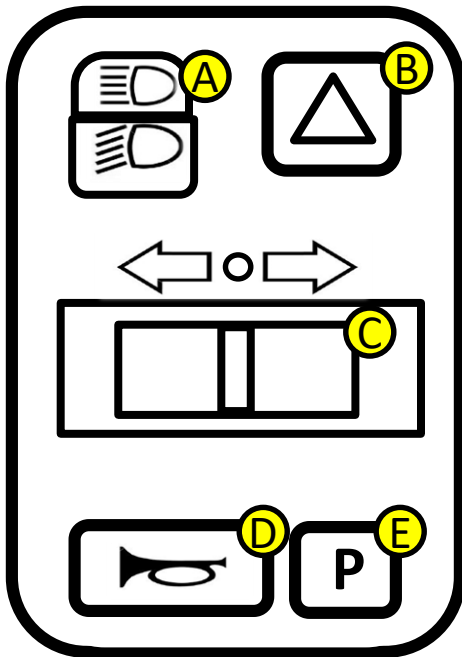

- A. High Beam Switch**  
When the top switched is pressed, the headlight changes from dipped to high beam.
- B. Emergency Signal/Hazard Lights**  
Operates the Emergency lights.
- C. Turn Signal Switch**  
When pushed right or left, corresponding turn signals are activated.
- D. Horn**  
When pressed horn sounds. Please use it gently when needed.
- E. Park Mode**  
Press to activate or disengage park mode. When the vehicle is first turned on, it is automatically in park mode. See more on “Quick ride” to undo Park mode.

## Right handlebar Switchbox

- A. Headlight Switch**  
Press to turn on or turn off the Headlight.
- B. Daylight riding light Switch**  
Press to turn the side lights on or off. In EEC markets, this switch remains turned on as per government regulations.
- C. Riding Mode Switch**  
This switch is used to switch Ride Modes. See more details in Ride Mode section
- D. Push Assistance Switch**  
Press this button while pushing the vehicle for a motorized assist.
- E. Reverse Mode**  
Press and rotate the throttle gently to move backwards. **Warning:** Always use caution while reversing. Some users will not be accustomed to reverse riding so the experience may take some practice.

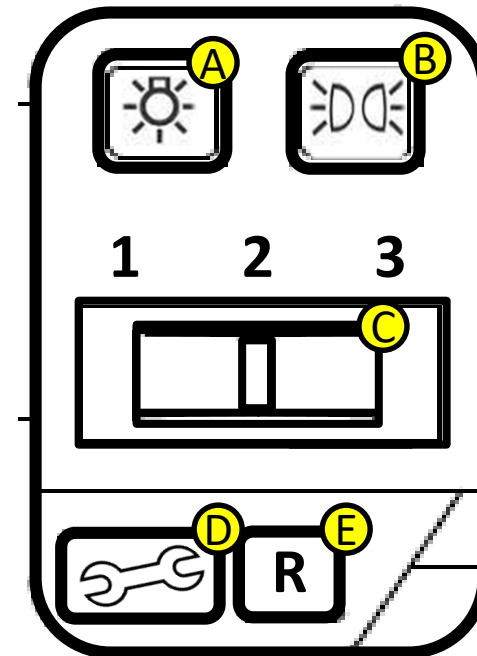

# Ride Modes

## Ride Modes

### To change Ride Modes

You will notice on your right handle bar switchbox, the options 1, 2 and 3. (1=Eco 2=City and 3=Sport ) as show in the image on the right.

Your chosen ride mode is displayed on the top of the TFT display as highlighted in yellow in the picture below.

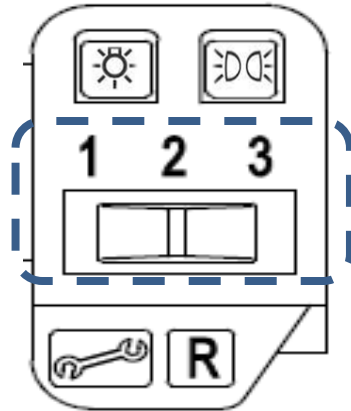

**ECO** mode reduces the acceleration and top speed to 60km/h and is designed for use in cities when the rider wants maximum range.

**CITY** mode keeps acceleration at a gentle yet usable level. The torque and power are increased over ECO, but less than SPORT. CITY mode is for urban environments where the rider does not need to exceed 90km/h.

**SPORT** mode provides the user with unrestricted performance. This mode will provide the lowest range performance so the user must keep an eye on the battery state of charge while using sport mode.



## TFT Display

- A. Riding Mode
- B. Time
- C. Motor Temperature
- D. Bluetooth
- E. 4G LTE Signal
- F. Speedometer
- G. Error Code
- H. Trip Distance Meter
- I. SOC
- J. Bike Status
- K. Output Power
- L. Odometer
- M. Battery temperature
- N. Estimated Range
- O. Power regenerative
- P. ESP
- Q. Park Mode
- R. Headlight
- S. Emergency Light



## Temperature Gauges

The battery (power pack) gauges are equipped with indicator bars that change colors depending upon their current temperature.



## Temperature Management

The battery (power pack) is designed to automatically manage the Temperature changes to ensure the safest possible temperature while riding.

In the event that temperatures rises beyond normal levels, the motorcycles system will automatically limit acceleration and performance to reduce the temperature back to safe levels.

In the unlikely event that your motorcycle motor or battery temperature raise high enough to trigger warning signs on the display, please stop as soon as possible and allow time for it to cool down. If the problem persists then reach out to your nearest dealer.

Do not ride your motorcycle at high temperature, it can damage the battery, cause unwanted injury or repair costs.

## Important Operating Information

Always turn the key switch and motor stop switch to the OFF position when not actively riding. It is very easy to forget that the motorcycle is powered on due to the lack of engine noise. Although the motor is disengaged when the kickstand is lowered, an accident can occur if the motorcycle is left powered up while getting on or off the motorcycle.

### **Do not hold the motorcycle's position on a gradient using partial throttle to avoid additional stress on the drivetrain**

The power pack should be plugged in when storing the motorcycle for extended periods of time. Keep your motorcycles connected to the charger when your motorcycle is sitting in storage or if it will be sitting unused for more than 30 days.

The power pack must be charged within 24 hours of being fully discharged and must be charged after 90 days of storage. Alrendo recommends you plug in your power pack after 90 days even if it is displaying that it is fully charged.

Please leave your power pack plugged in whenever possible.

**WARNING!** Only charge the power pack with the Motorcycle's on-board charger. Do not attempt to bypass the on-board charger.

The power pack does not require, or tolerate, deep discharging. To get the most power pack life, recharge each power pack immediately after each ride. Leaving a power pack in a discharged state will cause damage.

Do not charge in temperatures below freezing and do not ride your motorcycle below -15 degrees Celsius.

Failure to follow power pack storage and charging instructions as described in this Motorcycles user manual may void the warranty of your motorcycle. These guidelines have been rigorously tested to ensure maximum power pack efficiency and service.

## Ignition Switch

Your TS Bravo is supplied with two keys. If one or both keys are lost, contact your nearest Alrendo Authorized Dealer for replacement options.

### Key Switch

#### A. Lock

Turn the handlebar all the way to the left, push down on the key, and turn the key counter-clockwise **past the B marker** to engage the steering head. No electrical circuits function.

#### C. Off

No electrical circuits are in operation.

#### D. ON

Insert the key and turn clockwise to the On position to power up the motorcycle.

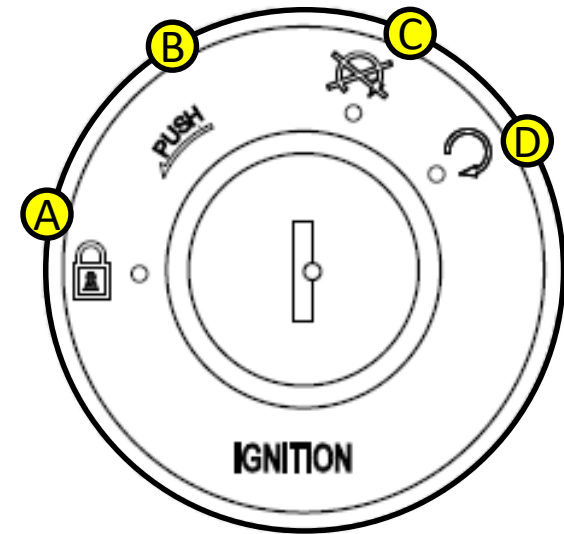

# How to Get Started

## How to Get Started

1. Turn the key to the  ition.
2. Lift the kickstand.
3. Hold either of the brake levers.
4. While your holding the brake lever, use your left thumb to press “P” button right next to the horn on the left handle bar switchbox .
5. The screen will display a green “Ready” which indicated that the bike is active and ready to ride.
6. Twist the throttle and go!

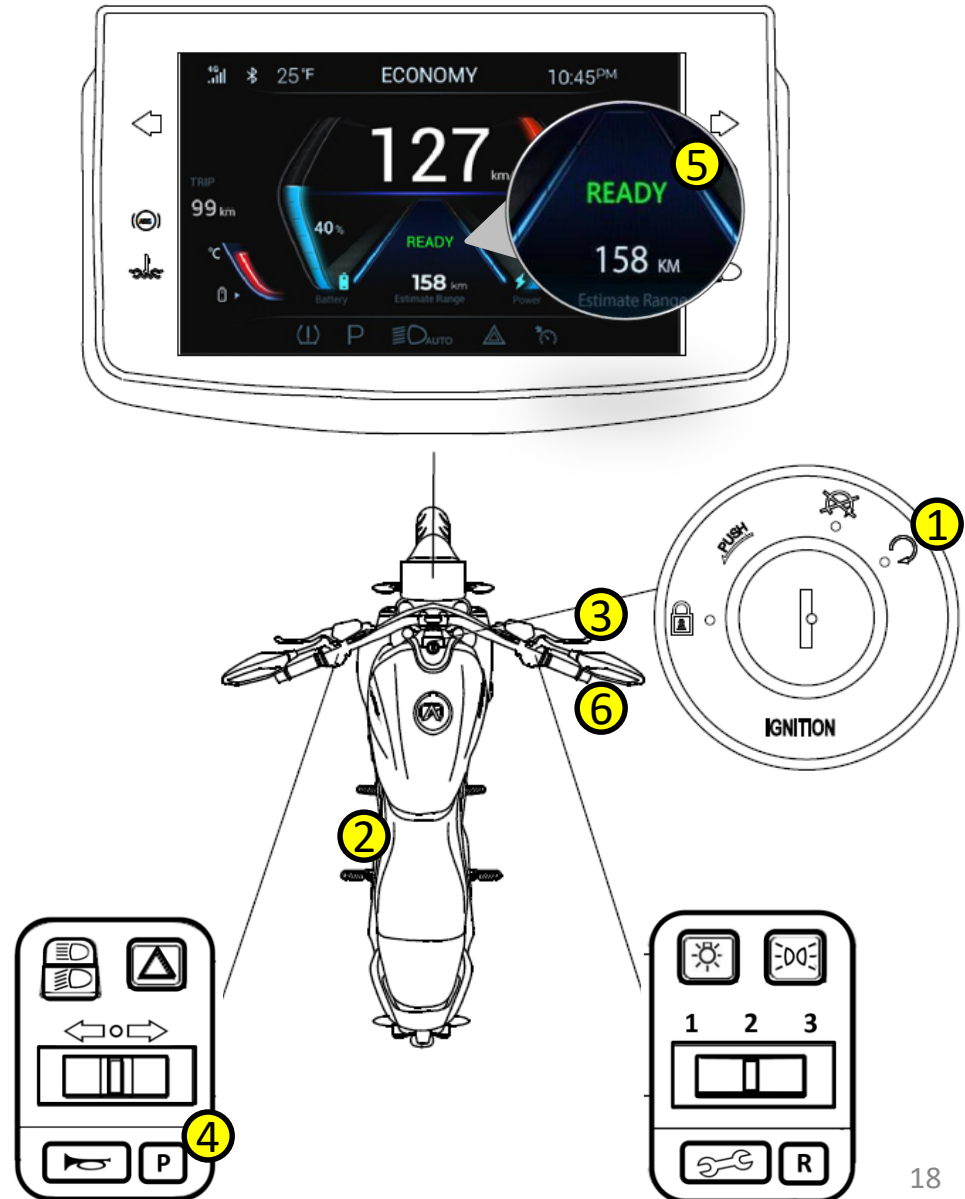

## Throttle Control

Twist the throttle in a counter-clockwise rotation.

**A** to power the motor and accelerate the motorcycle in forward direction.

Release the throttle and it snaps back to the closed position **B**, disengaging the motor.

When the motorcycle is moving and the throttle control is in the fully closed position, the regenerative braking function will activate.

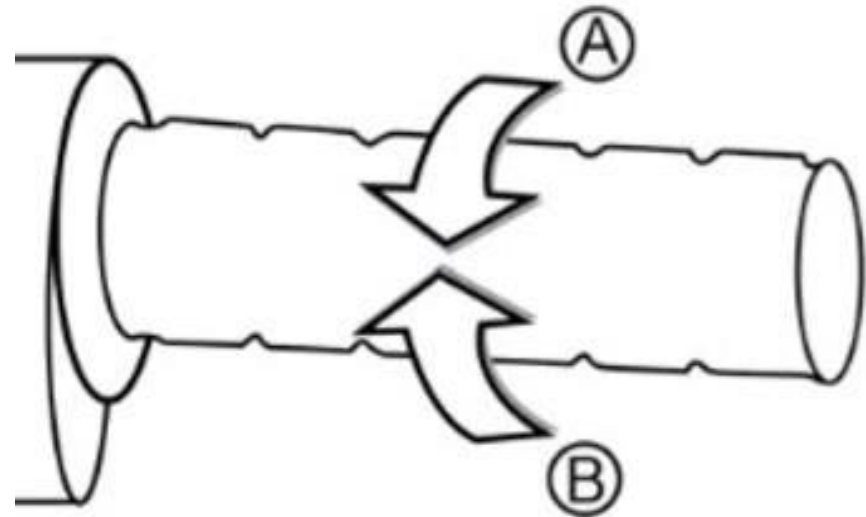

## Charging

Plug the Charging gun into charging port (as show in the image below with the blue arrow) and either connect to a 220v plug socket or activate the charging station.

It takes roughly 4 hours to fully charge the bike from 0-100% although it can take longer if charging under 16amps @220v.

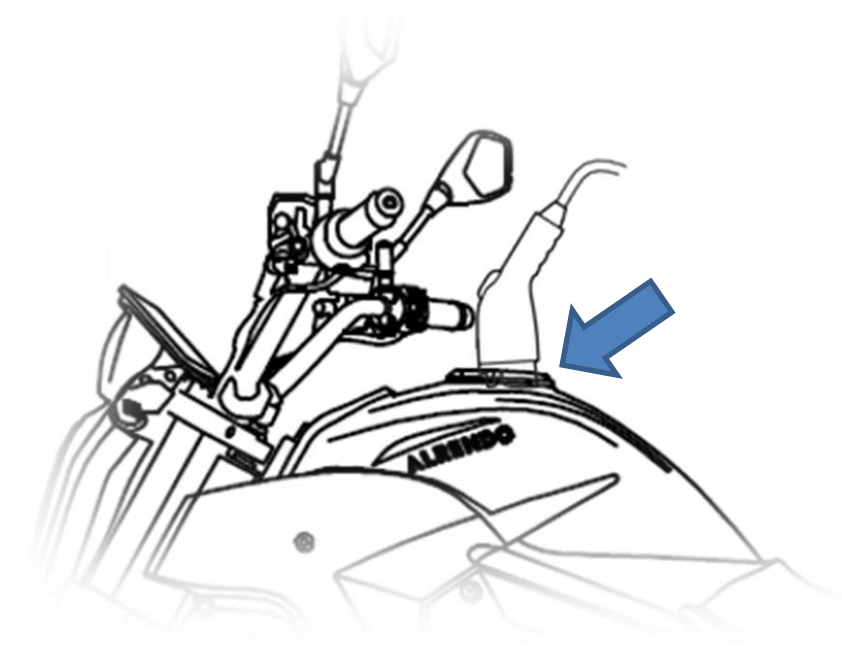

## Precautions for using the Alrendo Charging Adapter

**WARNING!** The Alrendo Charging Adapter should only be used with an electrical outlet that supports heavy duty service and a 13 to 16-amp continuous load. If you are unsure whether an outlet has this capability, have a qualified electrician inspect and verify it.

**WARNING!** Only use an outdoor electrical outlet if it is weatherproof when in use.

**WARNING!** Do not submerge or allow the charging port to be exposed to water when charging.

**WARNING!** Do not use extension cords, power strips, splitters, grounding adapters, surge protectors or any similar device with the Alrendo charging cable.

**WARNING!** Do not use on an electrical outlet that is supporting other electrical devices.

# Charging and Storing

**WARNING!** Do not use the Alrendo charging cable if the cable becomes frayed, has exposed insulation or wires or shows any significant damage.

**WARNING!** Do not use the Alrendo Charging Adapter if the plastic enclosure or the charging connector is broken, cracked or shows any significant damage.

**WARNING!** The Alrendo Charging Adapter must be properly grounded. If the Alrendo Charging Adapter should malfunction, grounding reduces the risk of electrical shock. If you are unsure whether an outlet has this capability, have a qualified electrician inspect and verify it.

**WARNING!** Do not use portable or backup generating equipment to charge the motorcycle. This may damage the Alrendo charging cable and the motorcycle's charging system. Only charge the motorcycle from utility supplier power.

After Plugging in your motorcycle, you will notice a charging battery icon along with details of the charging status. Only charge the motorcycle while it is turned off.

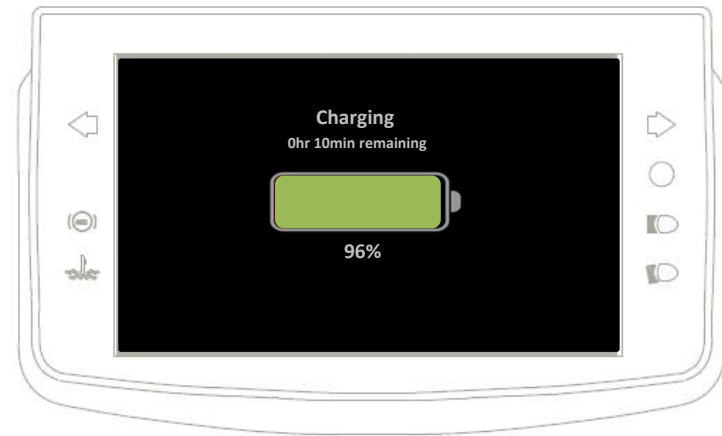

## Battery Pack

The maximum power pack internal charging temperature is 55°C. If the battery pack's internal temperature is over 55°C, it will not accept a charge until it is moved to a cooler location. Also, if the battery pack has just been run hard, it may internally be above 55°C even if the ambient temperature is lower.

The Minimum battery pack internal charging temperature is 0°C. If the battery pack's internal temperature is lower than 0°C, don't charge the power pack

**WARNING:** Always charge the power pack in a location that is well-ventilated and away from combustible materials. If charging your motorcycle outdoors, avoid charging in the rain.

**WARNING:** Never store your motorcycle at a state of charge less than 30%. Leaving the power pack discharged below 30% for a long period of time could damage the power pack and void the warranty.



## Cleaning

**WARNING:** Improper cleaning can damage electrical components, cowlings, panels, and other plastic parts. Although you can clean the TS Bravo with a pressure washer, avoid spraying high pressure water around the display, charge port or exposed cables. If tar, bugs, or other similar deposits have accumulated, clean them off as soon as possible to protect the paintwork.

**WARNING:** Do not use any harsh chemical products on plastic parts. Be sure to avoid using cloths or sponges which have been in contact with strong abrasive cleaning products, solvent or thinner, fuel (gasoline), rust removers or inhibitors, brake fluid, antifreeze, or electrolyte.

1. Wash your motorcycle with a sponge or a clean soft cloth, mild detergent, and plenty of water.
2. Use care when cleaning the plastic parts (display, top and side panels), which can scratch more easily than the other parts of your motorcycle.
3. After washing, rinse your motorcycle thoroughly with plenty of clean water to remove any detergent residue.
4. Dry your motorcycle with a chamois or a soft, dry towel.
5. After cleaning, inspect for damage, wear or leaks.

**WARNING:** After cleaning and before starting your journey, always test the brakes.

# Cleaning Your Motorcycle

## Storage

Before storing your bike, clean and polish it. This will help keep the bike look newer for longer, it also makes it easier to inspect and service. Do not expose your bike to harsh detergents or chemical solvents, as this could damage its metal, paint, or plastic.

Whenever you plan on not riding or storing your motorcycle for extended periods of time (more than 30 days), it is recommended that you charge the power pack to approximately 60% state of charge (SoC) and then leave the charger disconnected.

The power pack will discharge extremely slowly over time. Check the SoC at least monthly and charge it back up to 60% if it has dropped below 30%.

If you are leaving the bike in storage for longer than 30 days and are unable to return monthly, fully charge the battery and check it after 3 months.

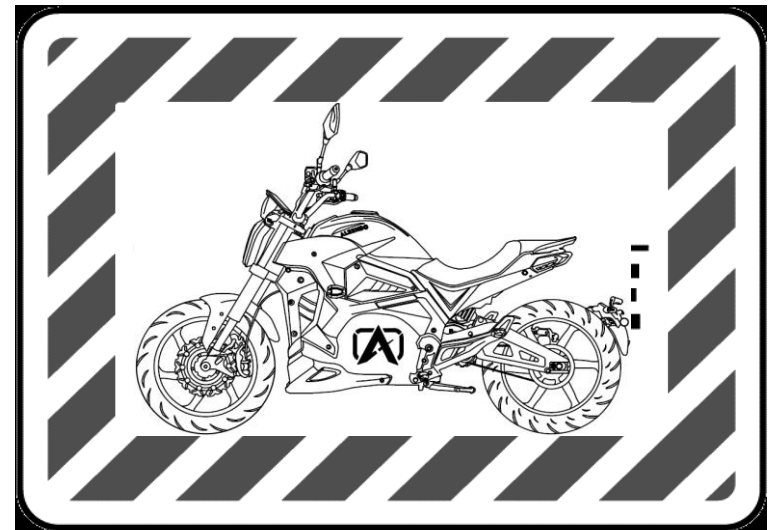

# Extending Your Range

The following factors must be taken into consideration if you wish to extend your range. The following riding conditions should be avoided.

A. Temperatures below 25°C

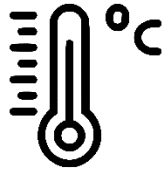

B. Sitting upright while riding



C. Carrying excess weight or passengers,



D. Accelerating hard



E. Improperly inflated tires



F. Mountainous terrain and elevated routes



**REMINDER:** Always remember to plan your route around charging stations if you are traveling long distances through rural areas.

## ABS Warning Indicator

It is normal for ABS warning light to glow when turning “ON” your motorcycle. It will automatically turn off a few seconds.

Riders must pay attention if ABS warning is indicator glows any other period. This indicates

- A. The ABS is disabled
- B. The ABS has malfunctioned

Rider must take their motorcycles to the nearest Alrendo Dealership to repair their ABS system at their earliest convenience. If you there are no dealers in your area, contact Alrendo at [info@alrendo.com](mailto:info@alrendo.com).

**WARNING:** Riding with a malfunctioning ABS System is very dangerous. Your braking will be unpredictable and you are more likely to experience the wheels locking up under heavy braking



## Your Responsibilities

- This rider's manual should be considered a permanent part of this motorcycle and the user is responsible to ensure they have the most up to date version.
- Perform routine care and maintenance of your electric motorcycle as detailed in this users manual.
- Use only Alrendo approved parts and Alrendo Motorcycles accessories.
- Always wear a regionally approved helmet, goggles, appropriate boots, and all other appropriate safety equipment when operating an electric motorcycle.

## Service History

Follow the maintenance schedules on as show in next page. After each scheduled service or routine is performed, record the information in the Maintenance Record chapter of this book.

# Maintenance



#	ITEM	ROUTINE	EVERY RIDE	INITIAL	INITIAL	ODOMETER MILEAGE READING			
				1000km or 1 month	7000km or 6 months	13000km or 12 months	19000km or 18 months	25000km or 24 months	30000km or 30 months
1	Brake Fluid (Right and Left)	Check brake fluid levels. Add brake fluid as necessary.	?	?	?	?	?	?	?
		Replace brake fluid (every 12 months).			?		?		
2	Front Brake	Check operation, and for fluid leakage. Replace brake pads if necessary.	?	?	?	?	?	?	?
3	Rear Brake	Check operation, and for fluid leakage. Replace brake pads if necessary.	?	?	?	?	?	?	?
4	Wheels	Check run-out, and for damage. Replace if necessary.			?	?	?	?	?
5	Tires	-Check tread depth, and for damage. Replace if necessary. - Check air pressure. Correct if necessary.	?		?	?	?	?	?
6	Wheel Bearings	Check bearings for smooth operation. Replace if necessary.		?	?	?	?	?	?

# Maintenance

#	ITEM	ROUTINE	EVERY RIDE	INITIAL	INITIAL	ODOMETER MILEAGE READING			
				1000km or 1 month	7000km or 6 months	13000km or 12 months	19000km or 18 months	25000km or 24 months	30000km or 30 months
7	Drive Belt	- Check belt tension. - Inspect belt for signs of damage or cracking. Replace belt: - Every 30000 km.	?	?					
8	Swingarm Pivot Bearings	Check bearings for smooth operation. Replace if necessary.							?
9	Steering Bearings	- Check for looseness. - Repack with all-purpose grease.		?	?	?	?	Repack	?
10	Chassis Fasteners	- Check all chassis fasteners and fittings. - Tighten and adjust as needed.			?	?	?	?	?
11	Front Brake Lever Pivot Shaft	- Apply silicone grease lightly. - Check operation. - Service/rebuild if necessary.		?	?	?	?	?	?
12	Front Fork	- Check operation and for oil leakage. - Service/rebuild if necessary.	?		?	?	?	?	?
13	Rear Shock Assembly	- Check operation and for oil leakage. Replace if necessary.	?		?	?	?	?	?

# Maintenance



#	ITEM	ROUTINE	EVERY RIDE	INITIAL	INITIAL	ODOMETER MILEAGE READING			
				1000km or 1 month	7000km or 6 months	13000km or 12 months	19000km or 18 months	25000km or 24 months	30000km or 30 months
14	Throttle Grip	- Check operation and free play.	☐		☐	☐	☐	☐	☐
15	Kickstand Pivots	- Check operation. - Apply silicone grease lightly.			☐	☐	☐	☐	☐
16	Kickstand Switch	Check operation and replace if necessary.		☐	☐	☐	☐	☐	☐
17	Drive Motor	Commissioning and timing.		☐		☐		☐	

# Torque Settings

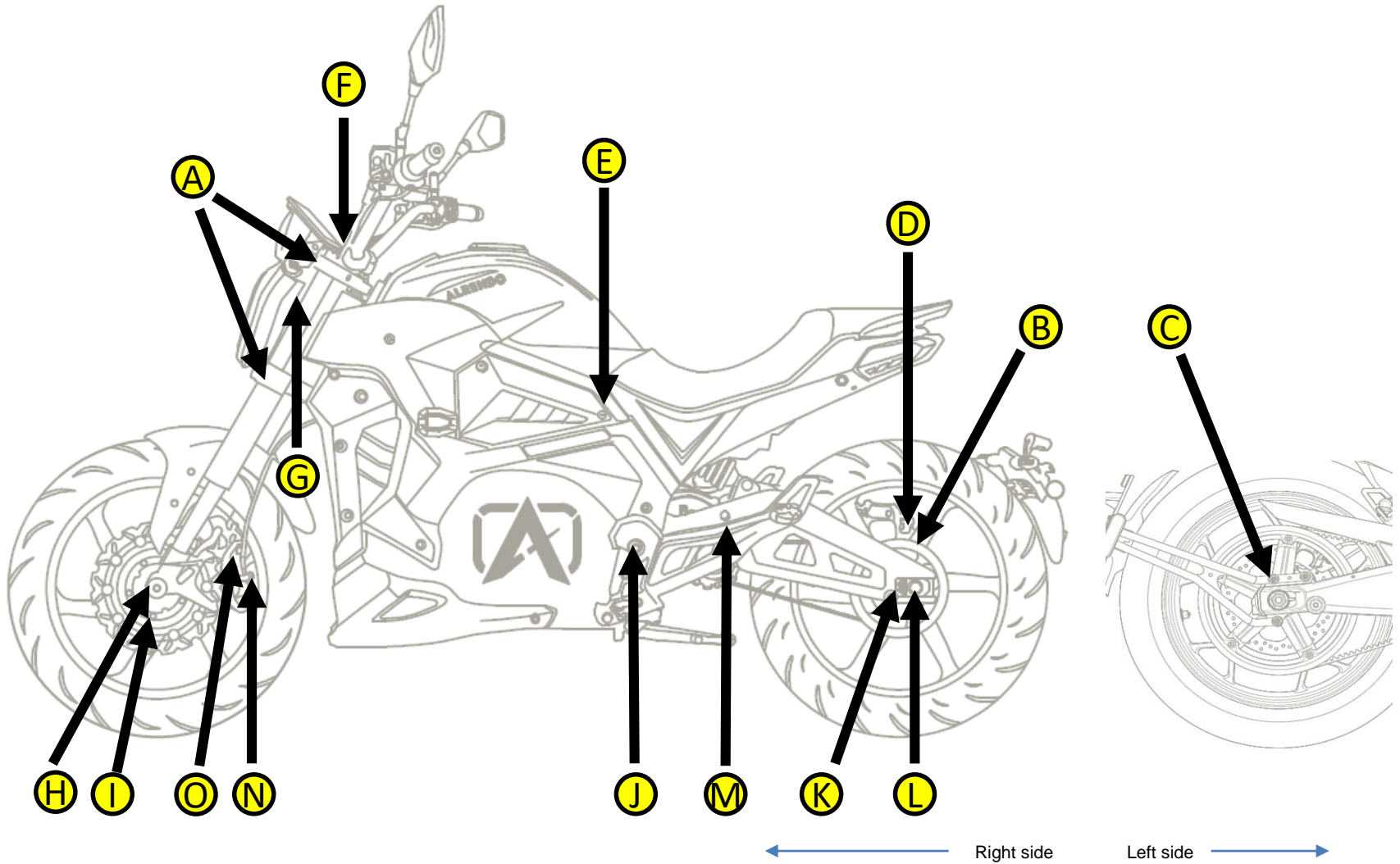

Make sure you do on both side if applicable

## Torque Settings

Periodically check and tighten the following fasteners on your motorcycle.

Location	Item	Torque	Notes
A	Upper/Lower triple clamps pinch bolts	16 lb-ft (22 Nm)	Use LOCTITE® 242® (or equivalent)
B	Rear sprocket to wheel bolts	26 lb-ft (35 Nm)	Use LOCTITE® 242® (or equivalent)
C	ROF arm bolts	20 lb-ft (27 Nm)	Use LOCTITE® 242® (or equivalent)
D	Rear brake caliper brake pad bolt	6.6 lb-ft (9 Nm)	Use LOCTITE® 242® (or equivalent)
E	Rear shock mount bolts	52 lb-ft (71 Nm)	-
F	Handlebar clamp mount bolts	19 lb-ft (26 Nm)	-
G	Headlight mount bolts	3.7 lb-ft (5 Nm)	Use LOCTITE® 242® (or equivalent)
H	Front axle	40 lb-ft (54 Nm)	Use LOCTITE® anti-seize lubricant (or equivalent)
I	Front axle pinch bolts	16 lb-ft (22 Nm)	Use LOCTITE® 242® (or equivalent)
J	Swingarm bolts	30 lb-ft (41 Nm)	Use LOCTITE® 242® (or equivalent)
K	Rear axle adjustment bolts	4 lb-ft (5.4 Nm)	Use LOCTITE® 242® (or equivalent)
L	Rear axle nut	75 lb-ft (102 Nm)	Use LOCTITE® 242® (or equivalent)
M	Motor mount side plate bolts	25 lb-ft (34 Nm)	Use LOCTITE® 242® (or equivalent)
N	Front brake caliper mount bolts	30 lb-ft (41 Nm)	Use LOCTITE® 242® (or equivalent)
O	Front brake caliper brake pad bolts	6.6 lb-ft (9 Nm)	Use LOCTITE® 242® (or equivalent)

# Brakes and Suspension

A. Front Suspension Adjustments

B. Rear Suspension Adjustments

C. Rear Brake

D. Front Brake



# Suspension – Front Adjustment

## Front adjustment

The TS Bravo uses Oil Filled front forks.

### Spring preload adjustment screws (both forks)

Adjusting the preload lets you change the “unloaded” sag of the suspension system. Turning the nut clockwise increases the spring preload and reduces the “unloaded” sag of the suspension system.

Turning the nut counter-clockwise decreases the spring preload and increases the “unloaded” sag of the suspension system

To adjust the spring preload, always start from the minimum preload position (nut turned fully counter-clockwise). Take note of number of turns and adjust both forks equally.

**CAUTION:** Adjusters should never be forced completely clockwise or counterclockwise; always leave one click of adjustment in either direction

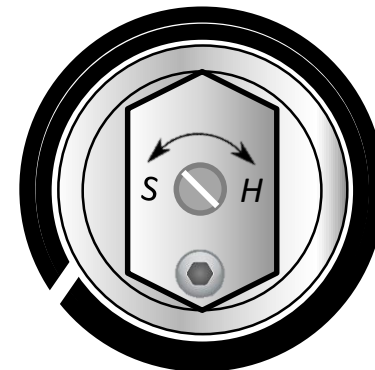
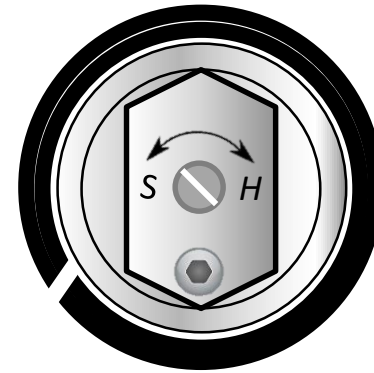

## Rear Adjustment

Adjust the spring pre-load by rotating the two pre-load adjusters:

Counter-clockwise to decrease the pre-load  
Clockwise to increase the pre-load

To adjust the pre-load back to the original setting used during manufacture, raise the rear wheel off the ground using a safety stand or a hoist. Rotate the pre-load ring counter-clockwise until it is loose. Then, rotate the pre-load ring clockwise four turns.

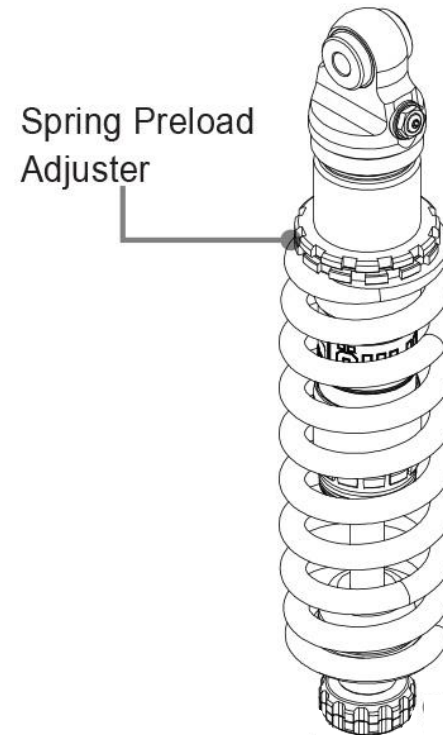

## Brake Fluid

The brake fluid reservoir is located on the backside of the right and left handlebars. Always be sure to check the brake fluid levels in your pre ride spot check.

Ensure the clear brake fluid liquid resides at 75%, between the Min and Max marks on the clear glass fluid monitoring section. If low, open the brake fluid reservoir with the 2 Philips head screws and fill with DOT4 brake fluid.

Make sure to close the reservoir tightly. Wipe down any brake fluid that has spilled over and ensure no paintwork is exposed to the fluid.

**WARNING:** Only use new fluid from an airtight container. Fluid from open containers will have absorbed moisture, which will adversely affect performance.



## Brake Fluid

**WARNING:** If the fluid comes into contact with the skin or eyes, rinse immediately with plenty of water.

**WARNING:** If the brake lever travel is unusually long, the feel is spongy or if there is any significant loss of brake fluid, contact your Alrendo Motorcycles Dealer. Riding under such conditions could result in extended stopping distances or complete brake failure.

## Brake Fluid Replacement

Brake fluid must be replaced every 12 months regardless of the distance the motorcycle has been ridden.



## Brake Pads & Brake discs

### Brake Pad Inspection

The brake pads must be inspected when specified in the maintenance schedule.

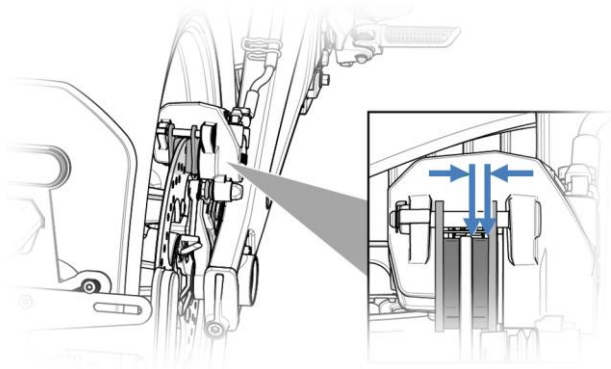

To inspect the condition of the brakes, examine the pads through the sides of the brake caliper.

Replace the brake pads if either pad's thickness is less than 1 mm. If the brake pads are worn they should be replaced immediately before riding

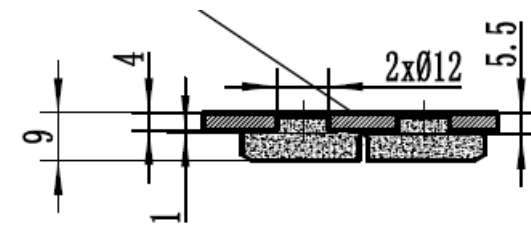

Inner

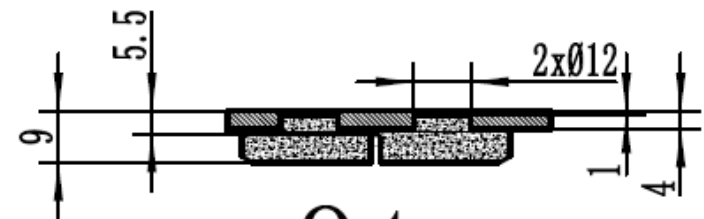

Outer

## Brake Pads & Brake discs

### Brake Disc Inspection

The thickness of the brake discs should be checked regularly. Replace brake rotor immediately, if less than the listed minimum thickness.

Rotor	Measurement
Front	4.5 mm
Rear	4.0 mm

### Brake Pad Replacement

After brake pads are replaced, the rider must bed in the brakes before riding at higher speeds. The brakes should be applied firmly 5 times from 50km/h to a stop to ensure any protective coating on the pads have been burned off.

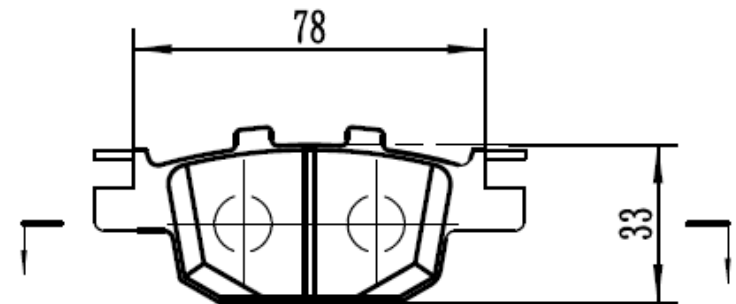
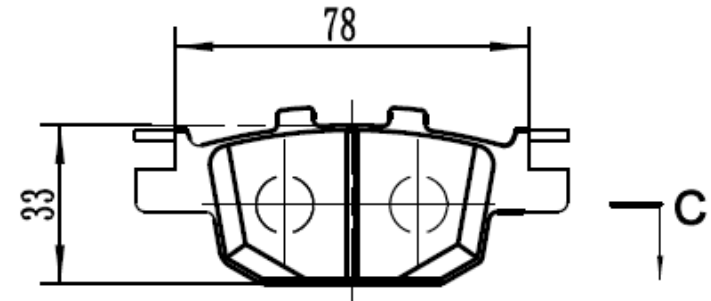

Inspect both tires for the following:

- Cuts, cracks, splits, or missing tread lugs in the tread or sidewall area.
- Bumps or bulges on the tire walls.
- Uneven tire tread wear. Wear on one side of the tire tread or flat spots in the tire tread indicate a problem with the tire or motorcycle.
- Exposed tire thread or cords.
- Tread depth below 1.6 mm.

If either of the wheels or tires are found to have any of the above conditions, replace the wheel or tire immediately.

## Tire Inflation

**WARNING:** Under-inflation is a common cause of tire failure and may result in severe tire cracking, tread separation, bead unseating from wheel, “blowout,” or unexpected loss of motorcycle control, causing serious injury or death

Front Tire	Rear Tire
36 PSI	36 PSI

Tire pressure should be checked and adjusted to the proper inflation level before each ride. Tire pressure should be checked using an accurate gauge when the tires are COLD.

**Note:** A COLD tire is defined as one that has not been ridden on for at least 3 hours.

**Note:** Always install the valve stem caps after adjusting the tire pressures.

## Tire Replacement

**WARNING:** Installation of non approved tires may cause adverse handling and performance problems and prevent the correct operation of the ABS. The tires fitted to the TS Bravo when homologated were up to the European testing standards. An

## Drive Belt

To prolong the life of your drive belt, clean the belt with mild soap and water when washing your motorcycle.

Once dried, inspect for the following:

- Cuts or unusual wear patterns.
- Damage to the center of the belt.
- Outside edge beveling. Some beveling is common but it indicates that sprockets are misaligned.
- Outside ribbed surface for signs of stone puncture.
- Inside (tooth portion) of belt for exposed tensile cords normally covered by nylon layer and polyethylene layer. This condition will result in belt failure and indicates worn sprocket teeth.
- Signs of puncture or cracking at the base of the belt teeth.

If any of the above conditions are found, the belt should be replaced.



## Drive Belt Adjustment Procedure

*Note: Adjust both sides (left and right) equally.*

1. Remove key from the key switch.
2. Use a wrench to screw in or out the bolt as per your need.
3. Use the line as reference to measure the difference, make sure you both side match on the same line.
4. Inspect the drive belt make sure it is not loose.
5. Tighten the bolt to Torque 102 Nm.
6. Test ride the motorcycle.
7. Recheck the belt for proper adjustment after the test ride and readjust, if necessary

## Gates Carbon Drive APP

For an accurate measurement of the condition of your belt, download the Gates Carbon Drive APP. The permitted frequency around 80hz.

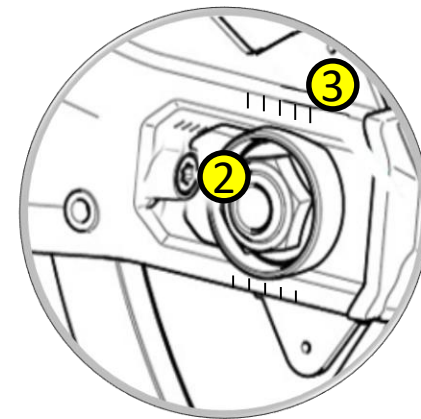

## Electric Motorcycle Precautions

Your Motorcycle has high voltage components. The high voltage used by these components is dangerous and can cause personal injury, severe burns, electric shock and even fatal injury unless appropriate precautions are taken.

Always observe and obey the instructions on labels attached to components on the vehicle - they are there for your safety. Do not touch, attempt to remove or replace any high voltage parts, wiring (identified by the orange outer sleeving) or connectors. If the motorcycle is involved in an accident do not touch any high voltage wiring connectors or the components connected to the wiring. If a motorcycle fire occurs, extinguish visible flame with a powder-type fire extinguisher.

**WARNING:** The motorcycle's high voltage system has no user serviceable parts. Disassembling, removing or replacing high voltage components, cables or connectors can cause severe burns or electric shock that may result in serious injury or death.

High voltage cables are colored orange for easy identification.

## Troubleshooting Your Motorcycle

All of the motorcycles are carefully inspected before they are delivered. Even after the motorcycles are inspected, some technical issues can occur. The following information (see next page Error codes) offers a guide to help you to identify an issue, and if possible, repair it yourself based on guidelines given in this user manual. If you are unable to solve an issue with your motorcycle, take it to an authorized dealer at your convenience. If there is no dealer in your area email Alrendo Motorcycles Customer Service.

## Error Codes

Communication Fault	4 {Fault_L1}	0x8101
Bluetooth Fault	2 {Warning_L2}	0x7001
GSM Fault	3 {WarningL3}	0x7002
GPS Fault	3 {WarningL3}	0x7003
RAM Fault	5 {Fault_L2}	0x6101
ROM Fault	5 {Fault_L2}	0x6102
Task Over Flower	5 {Fault_L2}	0x6103
Start-Stop-Button Fault	4 {Fault_L1}	0x5001
Turn Button Fault	4 {Fault_L1}	0x5002
Shift Button Fault	4 {Fault_L1}	0x5003
Side_Stand Fault	4 {Fault_L1}	0x5004
Backup battery Warning	4 {Fault_L1}	0x5005
MCU Temp	3 {WarningL3}	0x4201
DCDC Warning	4 {Fault_L1}	0x5006
BMS Power	5 {Fault_L2}	0x5007
ECU Power	5 {Fault_L2}	0x5008
HMI BMS Power	5 {Fault_L2}	0x5009
Logic Power	5 {Fault_L2}	0x5010
Mech Key	4 {Fault_L1}	0x5011
DCDC1Out1 Fault	5 {Fault_L2}	0x3301
DCDC1Out2 Fault	4 {Fault_L1}	0x3302
DCDC2Out1 Fault	4 {Fault_L1}	0x3303
DCDC2Out2 Fault	3 {WarningL3}	0x3304
ECU Missing	4 {Fault_L1}	0x7011

BMS Missing	4 {Fault_L1}	0x7012
K-BOX Missing	4 {Fault_L1}	0x7013
HMI Missing	4 {Fault_L1}	0x7014
ECU-Fault		0x7111
BMS-Fault		0x7112
ECU_Power Fault		0x7113
ROM CHECK fault	4 {Fault_L1}	0x5000
RAM CHECK fault	4 {Fault_L1}	0x5001
outside temp sensor fault	4 {Fault_L1}	0x5002
brightness sensor fault	4 {Fault_L1}	0x5003
file error	4 {Fault_L1}	0x6000
r/w spiflah error	4 {Fault_L1}	0x5004
ram full error	4 {Fault_L1}	0x6002
balance sensor fault	4 {Fault_L1}	0x5005
hmi high temp warning	1 {Warning_L1}	0x4200
hmi high temp fault	3 {WarningL3}	0x4201
hmi low temp fault	3 {WarningL3}	0x4202
hmi low temp warning	1 {Warning_L1}	0x4203
can transmission error	4 {Fault_L1}	0x8100
iap r/w saving data error	4 {Fault_L1}	0x5006
sys data error, parameter is out of range	4 {Fault_L1}	0x8200
Handle Lock Fault	3 {WarningL3}	0x5001
Other Lock Fault	2 {Warning_L2}	0x5002

## Cold Weather

Cold weather operation of the motorcycle has no permanent impact on its power pack/cells; however, the rider may see a reduction in range due to the effect cold temperature has on the amount of energy the pack/cells can release. The colder the weather, the greater the effect; so that, as compared to operation in 27°C ambient, at -1°C ambient, the rider could experience a temporary reduction in range of up to 30%.

## Hot Weather

Operation of the motorcycle in hot temperatures should not result in any noticeable performance changes. However, the BMS will not allow the to operate if the battery temperature gets too hot or the motor reaches 180°C.

*Note: Storing the motorcycle or its power pack in direct sunlight in ambient temperatures above 105°F (41°C) may result in accelerated permanent decay of power pack performance, and hence it is not recommended.*

## In the event of a collision

Do not puncture **RED AREAS** on image. **NEVER** cut high voltage components or cabling. Cutting the cabling could result in serious injury or death.

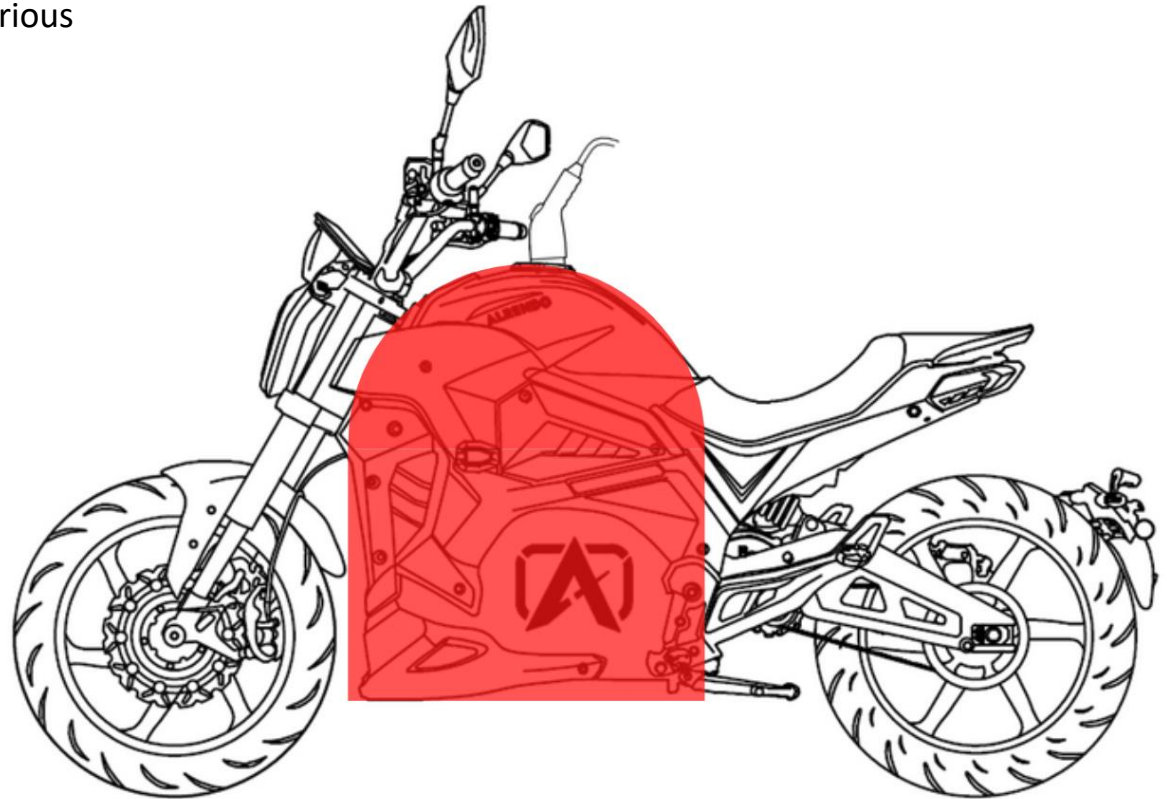

# Maintenance Records



After you have had your TS Bravo serviced, please make sure that the appropriate maintenance record has been completed.

Odometer:		Odometer:	
Date:		Date:	
Notes:		Notes:	
Performed by:		Performed by:	
Odometer:		Odometer:	
Date:		Date:	
Notes:		Note:	
Performed by:		Performed by:	

# Maintenance Records



Odometer:		Odometer:	
Date:		Date:	
Notes:		Notes:	
Performed by:		Performed by:	
Odometer:		Odometer:	
Date:		Date:	
Notes:		Note:	
Performed by:		Performed by:	

# Maintenance Records



Odometer:		Odometer:	
Date:		Date:	
Notes:		Notes:	
Performed by:		Performed by:	
Odometer:		Odometer:	
Date:		Date:	
Notes:		Note:	
Performed by:		Performed by:	

## Who does this warranty cover?

Alrendo warrants that each Product is free from defects in material and workmanship during the period of this warranty.

This warranty covers parts, including battery, motor, frame, swing-arm, motor controller, wiring, brake assemblies, wheels, throttle, fairings and any accessories approved by Alrendo which were installed prior to or at the time of delivery of a Product by a person authorized by Alrendo.

Accessories supplied following delivery of a Product are not covered by this warranty but may be covered by their own warranty.

Motorcycles which have been modified prior to sale other than by Alrendo or a person authorized by Alrendo, do not have the benefit of this warranty.

## This warranty does not apply to a Product unless:

It was supplied by Alrendo or through a person authorised by Alrendo;

The Dealer and any dealer or end user have followed the instructions set out in the Product's manual, including without limitation in relation to charging of the battery; and

The Dealer, any dealer or any end user has performed routine maintenance and servicing in accordance with the Product's manual, including without limitation having the Product serviced in accordance with the schedule set out in the Product's manual.

**This warranty does not cover repair of damage or replacement of parts to the extent caused by abuse or neglect of the Product. Examples of this include (without limitation):**

Any damage that results from use of the Product for race, rally or similar competitive sports;

Any damage that results from operating methods other than those indicated in the Product's manual or use beyond the limitations or specifications specified by Alrendo (maximum load, passenger capacity, engine speed and others);

Any damage that results from use of non-genuine parts or from use of lubricants, liquid agents or charging voltages with specifications different from those indicated in the Product's manual;

Any damage that results from modifications not approved by Alrendo (vehicle performance modifications, changes to lights, changes to motor controller settings, charger modifications and other changes);

Any damage that results from repairs of modifications; and

Any damage that results from the passage of time (natural fading of painted surfaces, plated surfaces and other deterioration).

## **This warranty does not extend to:**

Products modified in any way from the standard specifications as described in the Product's manual, including any Product whose odometer has been altered;

Normal wear and tear, corrosion and routine maintenance, such as the recommended service inspections;

Products from which identification numbers have been removed or whose identification numbers have been altered or mutilated;

Cosmetic concerns that arise as a result of environmental conditions, owner abuse, misuse, lack of routine care and maintenance, and/or improper use;

The cost of parts and labour involved in any routine care and maintenance and/or the replacement of parts due to normal wear and tear, use, or deterioration, including but not limited to oils and lubricants, light bulbs, tires, brake pads and rotors and fuses;

Inconvenience, cost of lodgings, cost of alternative transportation, loss of time, loss of income or loss of use of the Product or any consequential damage or economic loss of any kind;

Damage, malfunctions, or performance problems caused by theft, fire, collision, accident, vandalism, explosion, submersion in water, improper storage or acts of god;

## **This warranty does not extend to:**

Storage costs, or transportation and shipping costs related to the performance of this warranty;

Damage, malfunctions, or performance problems caused by continued operation of the Product after a warning light, gauge reading, or other warning indicates a mechanical or operational problem;

Products severely damaged or declared to be a total loss by an insurer, or Products substantially reassembled from or repaired with parts obtained from another used motorcycle; or

Damage, malfunctions, or performance problems caused by airborne industrial pollutants (e.g., acid rain), bird droppings, tree sap, stones, flood water, windstorms, or other similar occurrences

## **How does this warranty apply to the battery?**

The battery supplied with the Product is the only battery covered by this warranty. In the case of removable batteries, spare or replacement batteries are not covered by Alrendo, but may be covered by their own warranty.

Owing to the battery chemistry, there is a normal, expected reduction in range/capacity that the battery supplied with the Product can yield over time and usage. Depending on use and storage conditions, batteries will degrade during the duration of this warranty. Batteries must be operated in accordance with the Product's manual to preserve capacity. Deep discharging of the battery (such that it reports 0% state of charge), operating the Product outside of operational parameters stated in the manual, or using charging equipment not approved by Alrendo, shall invalidate the warranty.

Alrendo will repair or replace pursuant to this warranty (subject to the limitations above) a battery that exhibits a nominal storage capacity reduction of greater than 20% of the published original nominal capacity, as demonstrated to the reasonable satisfaction of Alrendo.

To check the capacity of a battery, Alrendo (or such authorized person) may request the Dealer to either download information from the battery management system or motor controller and send it to Alrendo, or discharge the battery into a dummy load. Tests will be conducted in conditions as determined by Alrendo.

# Dimensions

